

Compact controller

DEGA UPA III

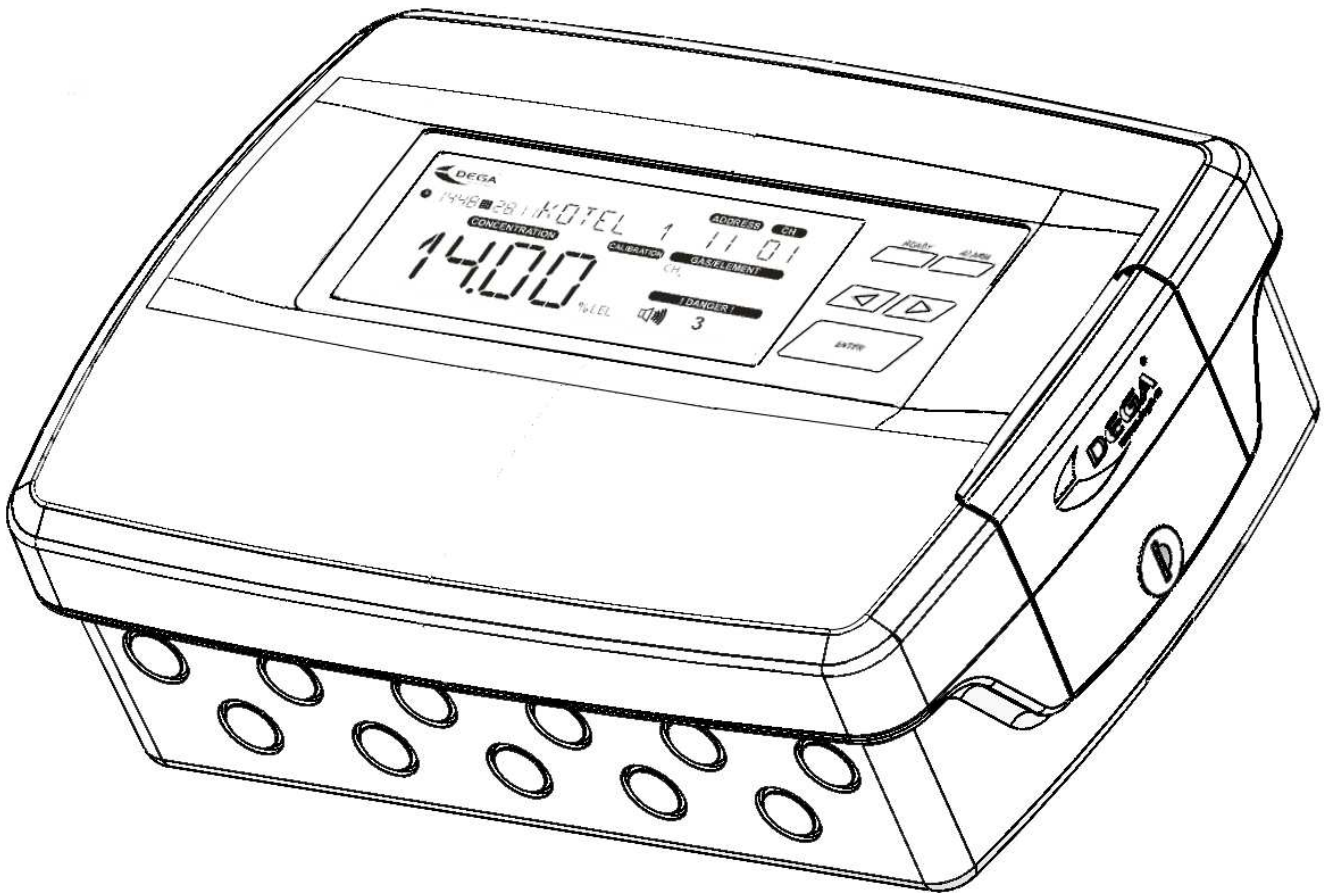

Reproduction of this manual, or any part thereof, in any form, without the prior permission of DEGA.CZ s.r.o. is prohibited



DEGA CZ s.r.o. reserves the right to alter the specifications of the hardware and software described in this manual at any time and without prior notice

DEGA CZ s.r.o. bears no liable for any damage resulting from use of this device

Content

For your safety	2
Technical data	3
Operational conditions	3
Product description.....	4
Outer case	4
Terminal block.....	4
Assembling and connecting the wiring.....	5
1. Assembly of the controller.....	5
2. Connecting a transmitter via current loop	5
3. Connecting a transmitter via RS485.....	5
Wiring installation for RS485.....	6
Termination resistor.....	6
4. Connecting the temperature sensor, float sensor and lay-off button of the beeper	6
5. Connecting the visual and acoustic alarms and the emergency valve	6
6. Selecting the supply voltage and the maximum current load	6
Supply voltage 230V AC	6
Supply voltage 24V DC	7
7. Output relay.....	7
8. Regulating the supply voltage.....	7
Controls.....	7
1. Panel	7
2. LCD display	8
3. Launch of the controller.....	8
4. Basic status/alarms	8
5. Malfunction.....	9
6. Monitoring the calibration periods.....	9
7. Reading the record of measured concentrations and alarms	9
8. Indication of past alarms.....	9
9. Automatic adjustment of the 0 point	9
10. Menu	9
History Menu HIST	10
Information menu INFO	10
Configuration menu CONF	10
Controller testing menu TEST.....	11
Service Menu SERV.....	11
Maintenance	12
1. Operation/Maintenance	12
2. Replacement of the battery.....	12
Add-on modules and accessories	13
Attachments.....	13
1. Table of error codes.....	13
General warranty terms and conditions.....	15

For your safety

Beware of static electricity



Electronic components are sensitive to static electricity. Do not touch them directly - they may get damaged.

The device is intended to be installed by a trained person



The product is designed for installation only by a certified technician. The manufacturer is not liable for damages resulting from incorrect or improper handling.

In case of malfunction, immediately unplug from the power supply



If you notice an unusual smell or smoke emitting from the product, unplug it from the power supply, battery backup and all other attachments. Continued operation could result in injury or property damage. After disconnecting, have the device inspected by an authorized dealer or manufacturer.

Do not disassemble the product and ensure against it's contact with water



Contact with internal components of the product may cause an electric shock. In case of any malfunction entrust the servicing of the product exclusively to a certified service centre. Contact with water can create a short circuit in the product and consequent damage to property or personal injury.

Use appropriate cable types



To ensure compliance with the parameters of the product, only use cable types recommended in this guide (see technical information – Wiring for connecting transmitters).

Dispose of used products with respect to the environment



Dispose of them in accordance with the current legislation on environmental protection.

Technical data

Supply voltage:	230 V AC/ 40VA 24 V DC/2 A nominal, operational range 20-28 V
Cable for connecting of the transmitters: via 4-20 mA: via RS485:	shielded cable 3 x 1 mm (max. 1200 m), or 3 x 1,5 mm (max. 2400 m) shielded cable 4 x 0,8 mm (max. 400 m) - see section "Wiring installation for RS485"
Cable for connecting the sensors: Temperature sensor DEGA Tc II: float sensor DEGA Zc II:	shielded cable 3 x 0,25 mm (max. 100 m) shielded cable 4 x 0,25 mm (max. 100 m)
Cable for connecting signalization and pushbutton cable	2 x 1 mm
Output:	USB (for PC configuration) RS485 - protocol DEGA, or MODBUS (on request) for the host system (PLC, PC) 10 x switching relays 250 V/10 A 2 x output for visual and acoustic alarms, max. load see chapter „Assembling and connecting the wiring“ paragraph 6
Input:	RS485 for connecting transmitters, max: 32 4-20 mA for connecting transmitters, max: 8
Communication speed of RS485:	9,6 kB
Functional safety EN61508:	SIL 1
Dimensions without bushings: Weight:	280 x 200 x 85 mm (WxHxD) 1,4 kg
Capacity of the internal memory of history: Interval record storage memory:	34 days at 60 s recording interval 60 s (adjustable range 1-255 s)

Operational conditions

Ambient temperature:	-20 °C to +60 °C
Relative humidity:	0-90 % RH
Air pressure:	80-120 kPa
Cover protection level:	IP 54
Location:	BE1 - non-explosive atmosphere

Product description

DEGA UPA III - The third generation compact evaluating controller is designed as a stand-alone device intended for mounting on a wall or on distributors. It is used to supply up to 32 transmitters via RS485 and up to 8 transmitters via current loop. It evaluates the gas leak of the transmitters in 4 levels. It is also possible to connect one float sensor DEGA ZC II and one temperature sensor DEGA Tc II. The status of each transmitter is indicated on the LCD display of the controller. The controller is equipped with 10 pieces of freely configurable relays, 2 outputs for visual and acoustic alarms, an output for impulsive closing of emergency valves, a USB port and a RS485 for connecting to the host system (PLC, PC with visualization).

Outer case



- 1** Cover
- 2** Bottom
- 3** Indents for bushings
- 4** Opening handle
- 5** LCD DISPLAY

Terminal block

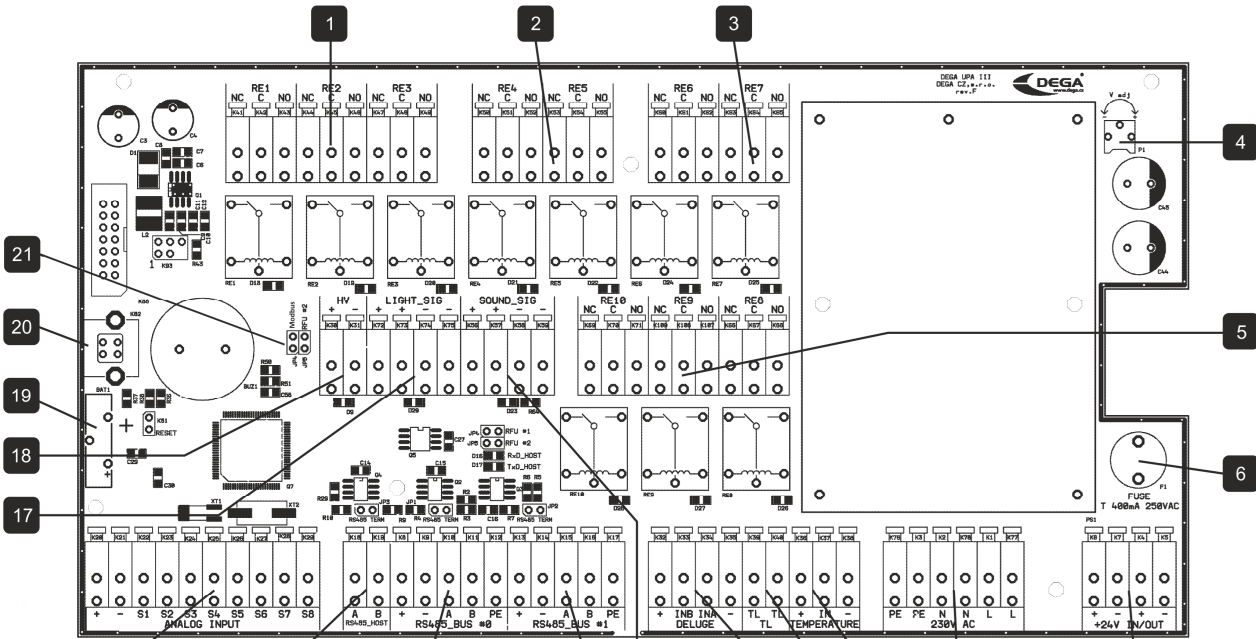

- 1** Terminal block relay RE1-RE3
- 2** Terminal block relay RE4 and RE5
- 3** Terminal block relay RE6-RE7
- 4** Trimmer for regulating the supply voltage 20-28V
- 5** Terminal block relay RE8-RE10
- 6** Fuse T400mA
- 7** Auxiliary input/output 24V DC
- 8** Power supply terminal block 230VAC
- 9** Temperature sensor terminal block
- 10** Acoustic alarm lay-key terminal block
- 11** float sensor terminal block
- 12** Acoustic alarm terminal block
- 13** Bus terminal block #1 for digital transmitters
- 14** Bus terminal block #0 for digital transmitters
- 15** RS485 for the host system
- 16** Analog inputs
- 17** Optical alarm terminal block
- 18** Emergency valve output terminal block
- 19** Backup battery for memory
- 20** USB connector
- 21** (unlabeled in text)

DegaConfig - adjustment software enabling full configuration of the controller

Assembling and connecting the wiring

Before assembling, read the valid installation standards EN 60079-29-2 (Selection, installation, use and maintenance of detectors for combustible gases and oxygen) and EN 45544-4 (Guidelines for the selection, installation, use and maintenance of detectors of toxic substances).

In explosive environments the electrical installation must be performed according to ČSN EN 60079-14 (Electrical installation in hazardous areas).

1. Assembly of the controller

- a) Pull the handle on the right side of the controller to unlock and lift the cover
- b) Drill the required amount of holes for bushings into the indents of the top and bottom part of the case
- c) Anchor the controller on a flat surface using four 6 mm fasteners
- d) Connect the wiring
- e) Close the cover of the case and lock the controller by using the handle

2. Connecting a transmitter via current loop

Connect one transmitter on each channel of the controller:

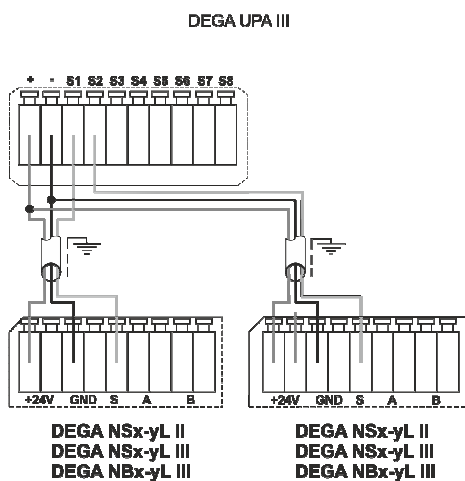

3. Connecting a transmitter via RS485

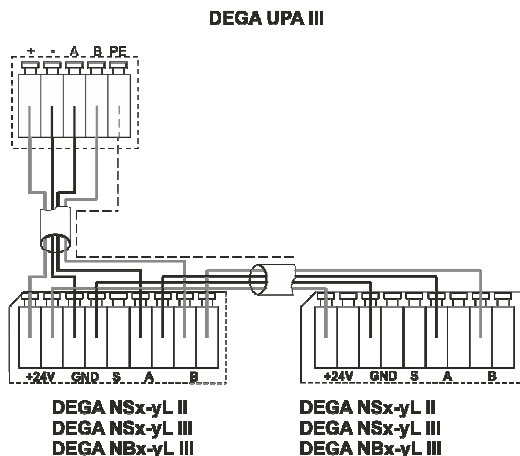

It is possible to connect up to 16 transmitters on each controller input, depending on their electrical distance from the controller.

Wiring installation for RS485

Wiring must be installed using bus topology and according to the RS485 principles.

Maximum number of connected transmitters per controller channel is 16 (may be less depending on the configuration of the controller), while the total length of the connecting cable (electrical distance between the controller and the last transmitter) should not exceed 400 meters. The maximal amount of transmitters connected to the bus and the type of cable used, according to the distance from the controller, is provided in the manuals of each transmitter.

Termination resistor



According to the RS485 specifications, the last device on the controller must be ending with a terminating resistor 120R. In the default configuration, the jumper connector is not plugged. There is a separate termination resistor for each bus, which is located behind the terminal block of the respective bus.

4. Connecting the temperature sensor, float sensor and lay-off button of the beeper

DEGA UPA III

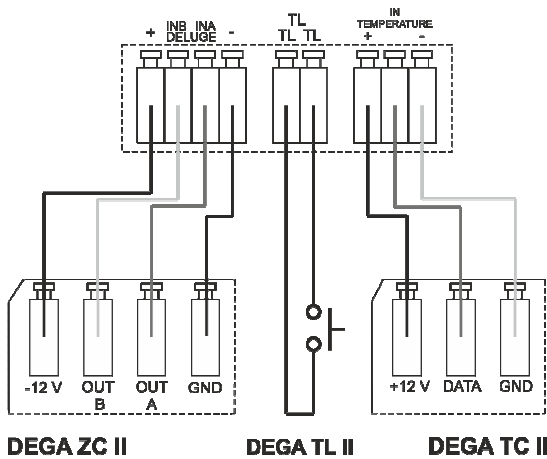

5. Connecting the visual and acoustic alarms and the emergency valve

DEGA UPA III

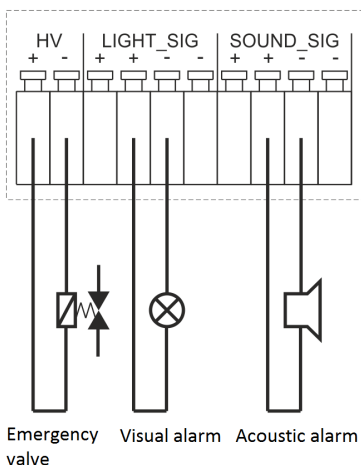

6. Selecting the supply voltage and the maximum current load

Supply voltage 230V AC

The highest current load of the controller is 1,4 A. This current serves to power the connected transmitters and the visual and acoustic alarms, which are connected to the terminal blocks „LIGHT_SIG“ and „SOUND_SIG“.

Example: There are 4 transmitters connected to the controller with a consumption of 60 mA each. The remaining 1,16 A ($I=1400-4 \times 60$) are used to supply the visual and acoustic alarms.

Supply voltage 24V DC

The consumption of the controller's electronics is 300 mA. Maximal current on terminal blocks „+24V IN/OUT“ is 10 A. Maximal current load on each output on terminal blocks „LIGHT_SIG“ and „SOUND_SIG“ is 4 A.

Example: There are 4 transmitters connected to the controller with a consumption of 60 mA each. The controller has a consumption of 300 mA. The remaining 7,46 A ($I=8000-300-4 \times 60$) are used to supply the visual and acoustic alarms.

Information on the consumption of each transmitter and component of the visual and acoustic alarms is provided in the respective manuals.

Never connect the supply voltage 24V and 230V simultaneously.

7. Output relay

Each relay can by default be configured to activate on any number and any combination of events:

Transmitter: 4 levels of gas leak alarms, PEL, STEL, transmitters malfunction

Controller: 2 levels of temperature, float, controller malfunction

After activation, relays can be configured for the following output functions: normally closed, normally open, cycling of open/close, automatic deactivation of deactivatable outputs after a certain time or after pressing a button.

Specific configuration of the relay can be determined using the Dega Config configuration program.

8. Regulating the supply voltage

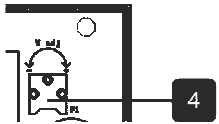

Using a trimmer, we can control the output voltage of the source in the 20-28 V range.

If the sensors are connected over a long distance, it may be necessary to increase the supply voltage for proper operation.

Controls

The control panel is equipped with a segmented LCD display and can be controlled using the LEFT, RIGHT and ENTER buttons. In Basic mode the controller displays the concentration and the states of the configured channels. Digital channels (transmitters connected via RS485) are numbered 1 to 32, and analog channels (connected via current loop) are in the range of 41 to 48. The controller sequentially switches between the configured channels (basic interval 3 s). For a longer display of a specific channel, briefly press ENTER (the channel remains displayed for 30 s). The ENTER button also serves as a confirmation key for switching-off of the off-switchable outputs of the controller. The respective output remains in the default state for as long as there is no fading of the event that triggered it (concentration drop, disappearance of the error code).

1. Panel

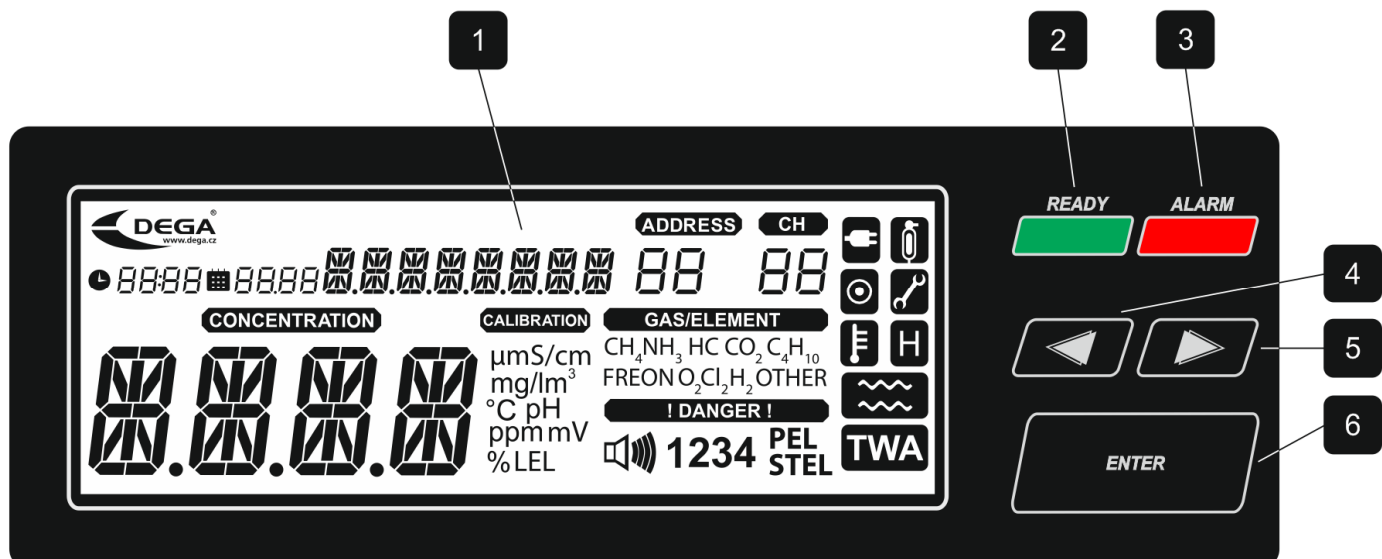

- | | | | |
|---|--|-------------------|--|
| 1 LCD display | 2 Indication of proper operation of the controller | 3 Gas leak | 4 LEFT button (move through menus, switch between transmitters) |
| 5 RIGHT button (move through menus, switch between transmitters) | 6 ENTER button (unlocking of the acoustic alarms and the latch function, confirm) | | |

2. LCD display

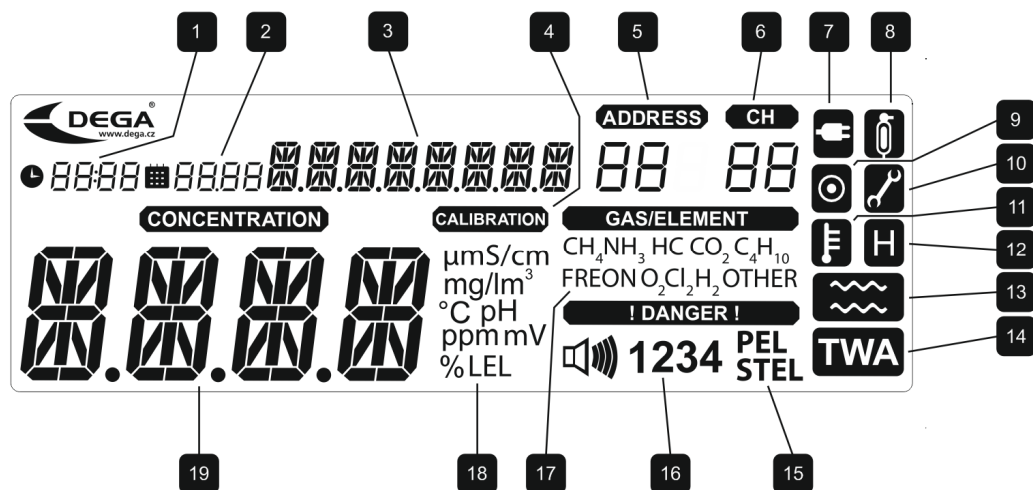

- | | | | |
|---|--|--|--|
| 1 Time | 2 Date | 3 Secondary display | 4 Warning: calibration required |
| 5 RS485 address of the current transmitter | 6 „Channel“ of the current transmitter | 7 Interrupted RS485 bus indication | 8 Transmitter calibration via RS485 |
| 9 Marker (selecting a transmitter in the menu) | 10 Malfunction of the controller or a connected transmitter | 11 Exceeding the critical temperature level | 12 Indication of an alarm record in the history |
| 13 float indication | 14 Exceeding the time-weighted average | 15 Alarm PEL - long-term exposure limit
Alarm STEL - short-term exposure limit | 16 Gas leak alarm, alarm levels |
| 17 Type of detected gas / substance | 18 Measured units | 19 Main segments of the display, currently measured concentration | |

3. Launch of the controller

After turning on the power supply, the whole LCD Display lights up and loads the highest measured concentration, which remains on the display for cca 3s. After that the controller goes into preheating mode. The main LCD displays a countdown to the end of preheating and the secondary segments display the inscription „HEATING“.

4. Basic status/alarms

The controller displays the concentration on 4 main segments. To its right, units and the detected gas are being displayed. The 8 auxiliary segments display the location or an eventual transmitter malfunction. If the displayed channel is digital **CH** (1 to 32), the address **ADDRESS** of the connected transmitter is also displayed. Connected analog transmitters **CH** have a range of 41 to 48. The controller sequentially switches the configured channels in a 3 s interval. If we want to select a transmitter manually, we can do so with the buttons LEFT and RIGHT.

The status of the sensor bundled with output relays (alarms, time-weighted averages, statuses of temperature sensors and floats, malfunctions) is displayed in the right part of the LCD.

In case of an increased concentration, the LED ALARM starts shining and the controller switches to the channel, which measured this concentration. After 30 s the channels will again be sequentially switched.

The latch function – catalytic and semiconductor sensors can, when exceeding the measuring range, indicate a lower measured value than it really is. If the measured concentration of these sensors exceed 100 % of the lower explosion level, the latch will activate. Even after a drop of the measured concentration, the transmitter will still be in it's highest alarm level. The

detection area must be physically checked by an independent transmitter and after that the controller can be unblocked by pressing the ENTER button.

The ENTER button also serves as an acknowledgment of the acoustic signaling.

5. Malfunction

If a malfunction should occur, the LCD displays the measured values, an error code and also a key symbol . The meaning of individual error codes can be found in the attachments (on page 13).



6. Monitoring the calibration periods

After 12 months since the last calibration (Max. calibration interval) an inscription **CALIBRATION** starts flashing on the LCD display. The connected transmitters must be calibrated immediately.

7. Reading the record of measured concentrations and alarms

The controller periodically, after 60 s, stores the current detected concentration into its internal memory. The internal memory retains data from the last 49 000 measurements (cca 34 days). In order to read this information, the program DegaConfig is required. Refer to the DegaConfig program instruction.

8. Indication of past alarms

The controller is equipped with an indication of alarms that have already gone off. If such an alarm was activated, the icon  is displayed. To view these alarms, enter the menu HIST → HILA, where the date and time since the highest measured alarm since resetting HIST → _RST is displayed for each transmitter. After viewing the history, it's possible to reset the counter through HIST → _RST and the icon  disappears.

9. Automatic adjustment of the 0 point

The connected digital transmitters have an inner diagnostic, which detects whether or not the 0 point is in disbalance. If so, an automatic adjustment will take place and the controller indicates this with the icon .

10. Menu

Enter the menu by pressing the ENTER button and hold it for cca 5 s. The main segments of the LCD display the menu functions. Use the arrows to move from one entry to another and press ENTER for selecting an entry. The last entry is always EXIT, which returns you to a higher menu level. The menu structure is as follows:

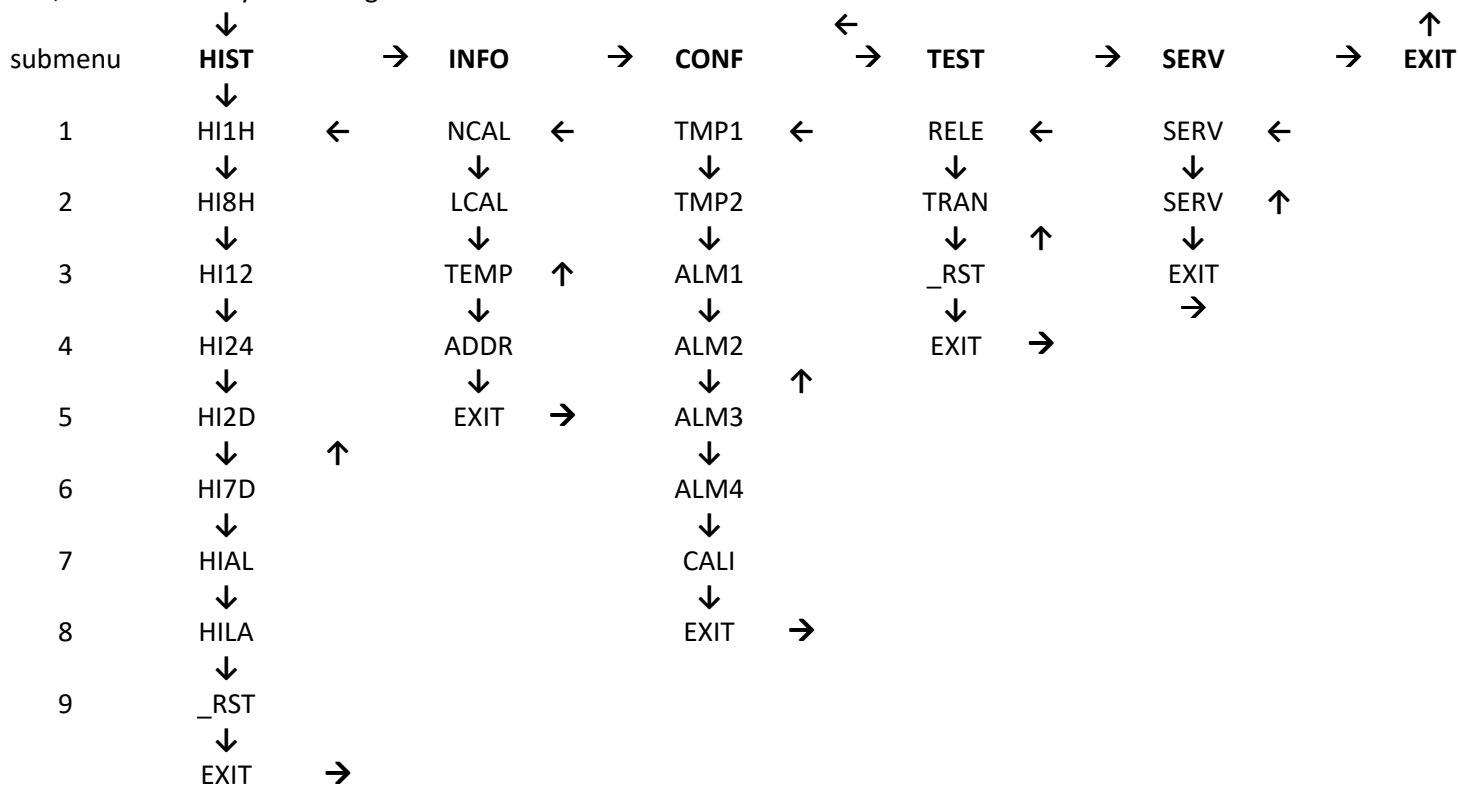

History Menu HIST

HI1	Displays the alarm history for the last hour
HI8	Displays the alarm history for the last 8 hours
HI12	Displays the alarm history for the last 12 hours
HI24	Displays the alarm history for the last 24 hours
HI2D	Displays the alarm history for the last 2 days
HI7D	Displays the alarm history for the last week
HIAL	Displays the alarm history for the entire memory (cca 34 days)
HILA	Displays the alarm history since the last reset of the entry _RST
_RST	Resets the time from which „HILA“ starts counting
EXIT	Returns to a higher menu level

This menu displays the highest measured concentrations in a selected time interval for each channel. There is a total of 8 intervals: - the last 1 h (HI1H), 8 h (HI8H), 12 h (HI12H), 24 h (HI24), 2 days (HI2D), 7 days, the entire memory (cca 34 days) and the interval since the last reset of „_RST“. Selecting an entry will perform a custom search in the memory for the selected channel. If the concentration hasn't changed and remained on the minimal value during the whole interval, „9999“ will be displayed instead of the date and time. Switch between the channels by using the arrows and use ENTER to return back to selecting a time interval.

The entry _RST serves for setting the time interval for the user alarm. If an alarm was activated at one of the transmitters since the last change of the entry _RST, the basic status of the controller displays the segment „H“. At the entry, the date and time since evaluation of „HILA“ are displayed. Pressing ENTER on this entry sets the interval to the current date and time and the segment H disappears from the basic display. Press ENTER again to return to the history menu.

Note.: In the case of equipping a larger quantity of transmitters, the loading of the history may take a few seconds.

Information menu INFO

NCAL	Displays the date of the next transmitter calibration
LCAL	Displays the date of the calibration
TEMP	Displays the temperature of the DEGA Tc II sensor
ADDR	Displays the controller address on the RS485 HOST bus
EXIT	Returns to a higher menu level

For entries „LCAL“ and „NCAL“ use the arrows to switch between individual transmitters. Moving to „NCAL“ displays the date and time of the next calibration for the selected sensor, which is connected via RS485. In addition, the main display shows the amount of hours remaining before the next calibration. In the same way, the entry LCAL shows the date and time of the last calibration for the selected channel. The main display again shows the amount of hours passed since the last calibration. This is a simple amount of hours, not the amount of hours, in which the sensor has been in operation.

The entry TEMP displays the current temperature from the temperature sensor, if it's configured and connected to the controller.

The entry ADDR displays the controller address on the RS485HOST bus.

Configuration menu CONF

To enter the menu, type in the password 0004. Use the arrows to change the value and use ENTER to move from right to left. Press ENTER to enter the CONF menu. Typing in a wrong password will return us to the measurement mode.

TMP1	Setting the critical temperature level 1
TMP2	Setting the critical temperature level 2
ALM1	Setting the 1. level of gas leak alarm
ALM2	Setting the 2. level of gas leak alarm
ALM3	Setting the 3. level of gas leak alarm
ALM4	Setting the 4. level of gas leak alarm
CALI	Calibration of the digital transmitters
EXIT	Returns to a higher menu level

The entries TMP1 and TMP2 change the temperature value of the external sensor at which an alarm occurs. Pressing LEFT decreases the temperature and pressing RIGHT increases the temperature. Press ENTER to confirm the change. **Attention**, the temperature alarm value changes immediately after pressing LEFT or RIGHT. If the immediate temperature value exceeds the alarm value, **it will change the output state**.

The entries ALM1 to ALM4 are used to set the alarm of the transmitters. Press ENTER to browse the alarms by using LEFT and RIGHT. Each channel shows the level of the alarm and the segment 1-4 lights up, based on the selected alarm. Press ENTER again to move to the edit mode. The segment 1-4 flashes and we can set the value by using LEFT and RIGHT. Pressing ENTER again will end the edit mode. **Attention, analog channel** value changes are immediate and so are the output changes. The changes are saved after pressing ENTER.

The entry CALI serves for calibration of the digital transmitters. LEFT and RIGHT changes the displayed channel and ENTER selects the channel (displayed ). Moving to the entry NEXT and pressing ENTER goes to zero-calibration of the selected transmitters. This mode displays a minimal AD conversion value on the main segment. The secondary segments display the maximal value. The oxygen detector is an exception, which always detects a 0 value in the zero-mode. By using LEFT and RIGHT it's possible to check the detected value of every selected transmitter and eventually wait for it to drop. Press NEXT to move to the calibration range mode. Inletting a calibration gas to the transmitter will start a concentration measuring of the calibration gas. The highest value of the AD conversion is displayed on the main display and the lowest value is displayed on the secondary segments. If we are satisfied with the values, we can move on to the next part by clicking NEXT, which will bring us to the settings of the calibration interval. This can be changed with LEFT and RIGHT and using ENTER will confirm the selection. In the final part of this whole process select either YES for saving the values into the transmitters, or no for finishing the calibration without saving the values.

Controller testing menu TEST

RELE	Setting the relay output
TRAN	Simulation of the measured values
_RST	Controller restart
EXIT	Returns to a higher menu level

The entry RELE is used for direct setting of the controller outputs. Entering this entry saves the current state of the outputs, which are later modified by the user. The controller outputs (RE1 to RE10, LIGH, SOUN, _HV) can be browsed with LEFT and RIGHT and pressing ENTER will switch the output state. The outputs will remain in these settings until we press ENTER on the last EXIT entry. That will restore the output state, which existed before the user change.

The entry TRAN is similar to the entry RELE, except for the fact that the user sets the concentrations on the given channel. Use LEFT and RIGHT to select a channel and then press ENTER to enter the edit mode. Here we can use the arrows to change the concentration ranging from minimal to maximal value of the configured transmitter. The controller reacts to this set concentration as if it was directly measured, which leads to the occurrence of alarms and switching of outputs.

The entry _RST resets the controller.

Service Menu SERV

The entry SERV ALL SENS makes the controller go into service mode. The communication with transmitter is stopped and the outputs are set in the last known state. Use LEFT and RIGHT to set the service interval in a range of 1 to 24 hours. Press ENTER to start it's own regime.

The main segments display a countdown of the set interval in seconds and the malfunction segments (key symbol) blinks. After the countdown finishes, the controller returns to the detection mode. This regime can be interrupted anytime by pressing ENTER.

The entry SERV SEL SENS causes a blockage of any transmitter until the next restart of the controller. Use LEFT and RIGHT to select a transmitter and ENTER to block/unblock. Blocked transmitters are indicated with an inscription DIS on the main segments.

1. Operation/Maintenance

In case of contamination the surface can be cleaned with a slightly moistened cloth. The connected transmitters require performing of regular checks and calibrations, which can be done in two ways:

- a) **1 x every six months** carry out a „**calibration**“ and **functional control** - adjust the sensitivity of the sensor using calibration gas and check the functionality of the system. The exact interval depends on the purity of the environment, required accuracy and the occurrence of disturbing gases in the atmosphere.
- b) **1 x every twelve months** carry out a „**calibration**“ - adjust the sensitivity of the sensor using calibration gas and check the functionality of the system. The exact interval depends on the purity of the environment, required accuracy and the occurrence of disturbing gases in the atmosphere. Also carry out a „**functional control**“ **1 x every three months** - checking the function of the entire detection system using a test gas, which does not exceed the range of the sensor. We recommend using gas intended for laboratory use.

For the „functional control“ do not use means for testing fire alarm detectors!

Perform calibration only at certified service centers with a valid certificate of competence or the manufacturer.

For the Czech Republic only DEGA CZ s.r.o.

2. Replacement of the battery

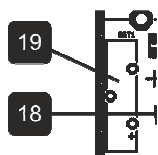

Energizer	2032
Duracell	2032
Varta	2032
Panasonic	2032

The battery lifetime in the controller is approximately 5 years. After this time some functions of the controller may not work properly. Remove the battery from the holder and replace it with one of the recommended types. Replacing the battery in the controller, which is not connected to the power supply, will erase the internal clock.

Add-on modules and accessories

Product code	Name	Product description
10200019	DEGA UPA III Power	Internal Power Supply 230 V AC/15VA
10200020	DEGA UPA III Relay Module	Internal Output, 7-relays, 250 V/10 A
10200021	DEGA UPA III RS485 Modbus RTU Module	Internal Output RS485 Modbus RTU
10200022	DEGA UPA III 4-20 mA Input Module	Internal Input 4-20 mA
10200023	DEGA UPA III Memory Module	Internal memory with battery
10300012	Cable Glands PG9 (10pcs)	

Attachments

1. Table of error codes

Occurs on digital channels (1 to 32)	Occurs on analog channels (41 to 48)	Displayed on the secondary segments	Cause	Solution
	X	„SENSOR E“	Interrupted current loop or faulty transmitter	Check the transmitter connection, otherwise contact the manufacturer
X		„ NO SENS“	Sensor is not present (EEPROM is not communicating)	Disconnect and reconnect the sensor, then restart the sensor by disconnecting and reconnecting the power
X		„UNK SENS“	Unknown sensor type	Contact the manufacturer
X		„ELCHEM E“	Type 2 sensor ID not found in the settings table LMP91000	Contact the manufacturer - FW update required
X		„SENS CRC“	CRC does not match the sensor EEPROM	Sensor error - contact the manufacturer
X		„LMP9 ERR“	LMP91000 does not respond	Sensor error - contact the manufacturer
X		„SEN MISM“	The set sensor ID does not match with the connected sensor	Checking the configuration of the sensor required
X		„ELFAILED“	EL sensor test error	Sensor error, only informative, subsides by itself
X	X	„ HEATING“	Transmitter is in preheating mode	Wait a few minutes, the transmitter will automatically enter measurement mode
X		„EE25 ERR“	Error reading the internal FLASH	Restart the transmitter. If the error persists, contact the manufacturer
X		„FLASHCRC“	Error reading the internal FLASH	Restart the transmitter. If the error persists, contact the manufacturer

X		„EEPR CRC“	Error reading the internal FLASH	Restart the transmitter. If the error persists, contact the manufacturer
X		„INFRA ER“	Infrared sensor error	Replace the sensor
X		„ CALIB18“	The device exceeded the maximum calibration interval by 50 %	Calibration is necessary
X		„COMM ERR“	The transmitter doesn't respond	Check the connection between the controller and the transmitter

General warranty terms and conditions

When following the instructions for installation, operation and maintenance, the manufacturer grants a guarantee of 24 months from the date of receipt for the product. Should the product purchased be put into operation by an entity other than the seller, the warranty period commences from the date that the product is put into operation, provided that the buyer ordered its commissioning within three weeks of its receipt. The customer expressly acknowledges that during the warranty period that extends beyond the length of the warranty period that is specified in the Commercial Code (the statutory warranty) s/he can neither require replacement of the product nor may s/he withdraw from the contract.

1. When claiming a product defect it is necessary to submit a proof of purchase that contains the following information: name and surname, name and business name, address and the warranty card, if the buyer received one from the seller. The validity of the warranty shall not be affected by non-compliance with the obligations related to the issuance of the warranty card.
2. Claims concerning the product (for a warranty repair only complete devices are accepted) may be filed during the warranty period only with the seller from which it was purchased; subsequently the seller is required to forward the product to an authorized service centre or to the manufacturer.
3. A condition for the recognition of the rights under the warranty is the installation of the product having been undertaken by an authorized person in possession of a valid certificate from the manufacturer.
5. Claims regarding a product defect that can be dealt with reasonably quickly and without additional consequences will be resolved by remedying the defect (repair) or by replacement of the product part, because in such a case it is a contradiction of the standard norms that the entire product shall be replaced (§ 616, paragraph 4 of the Commercial Code).
6. The buyer who exercises the right of warranty repair is not entitled to the return of the parts that have been replaced.
7. The warranty period can be extended for up to 48 months and its validity can be extended beyond the standard length on the basis of the conclusion of an individual warranty contract. Further information may be obtained through a specific business meeting.

This warranty is not applicable to:

- a product that has not **been put into operation by the manufacturer or by a certified employee** in possession of a valid certificate issued by the manufacturer
- A product that did not have regularly performed calibrations and functional checks by the manufacturer or by a certified employee in possession of a valid certificate issued by the manufacturer.
- damage caused by fire, water, static electricity, power surges in the electric supply or in the public network, accident, improper use of the product, wear and tear
- contamination of the product and its subsequent cleaning
- damage caused by **improper installation, any adjustment, modification** or improper manner of use inconsistent with the instruction manual, the technical standards or the applicable safety regulations in the Czech Republic
- damage to the product during transportation caused by improper handling or handling of the product in a manner contrary to the advice provided in the instruction manual
- DEGA products that have **been used in association with other than original DEGA products**, including consumables and accessories
- bearing additional parts or consumables (e.g. a foil label, seal, etc.), that are detrimental to normal wear and tear during operation, together with wear and tear of the product and its parts caused by their normal use

For the complete version of the general business conditions and of the claims procedure go to www.dega.cz

Manufacturer: DEGA CZ s.r.o., Malešická 2850/22c, 130 00 Praha 3, Czech republic
VAT: CZ 279 029 43, Telephone: +420 774 447 660, E-mail: info@dega.cz, Web: www.dega.cz

© 2021 DEGA CZ s.r.o.



User Manual ver.: 2021.08.09.8/27/2021 2:16:00 PM

