

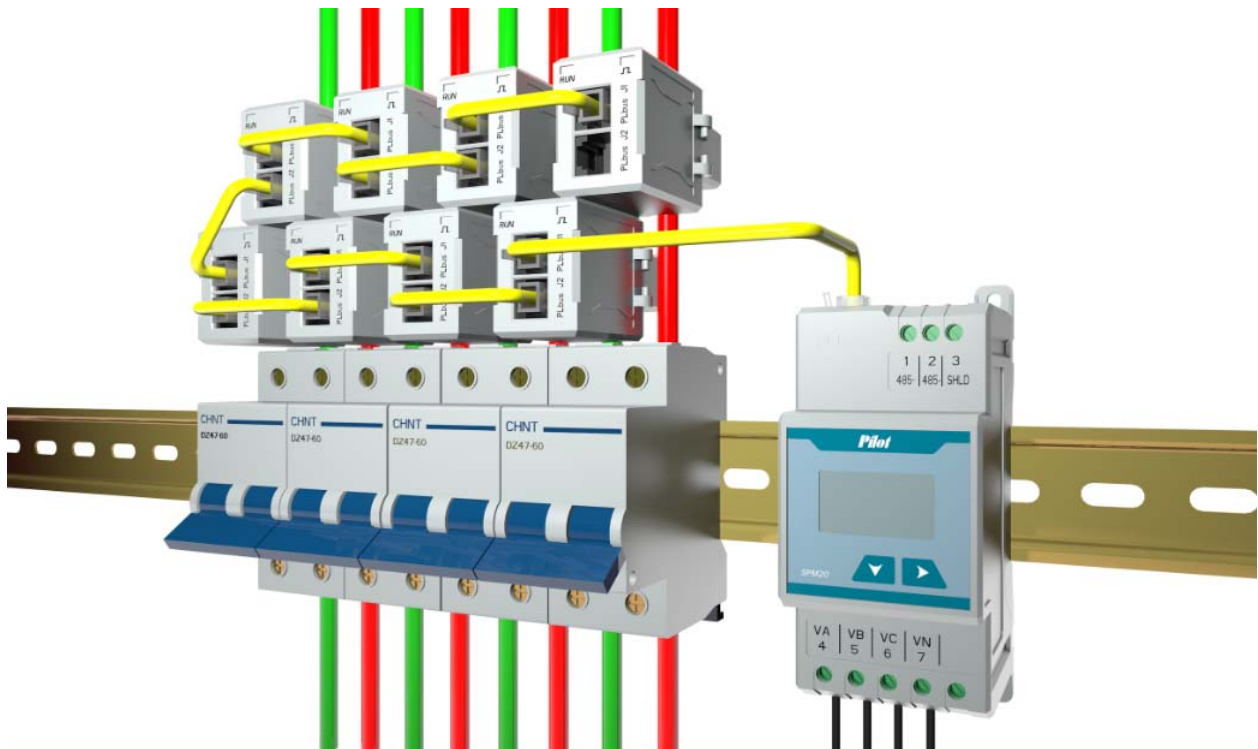

SPM20 Circuit Monitoring System

Installation & Operation Manual V0.4





Danger & Warning

- This device can be installed only by professionals.
- The manufacturer shall not be held responsible for any accident caused by the failure to comply with the instructions in this manual.



Risks of electric shocks, burning, or explosion

- This device can be installed and maintained only by qualified people.
- Before operating the device, isolate the voltage input and power supply and short-circuit the secondary windings of all current transformers.
- Use appropriate voltage tester to make sure the voltage has been cut-off.
- Put all mechanical parts, doors, or covers in their original positions before energizing the device.
- Always supply the device with the correct working voltage during its operation.



Contents

Chapter 1 General Information.....	4
Chapter 2 Product Type	5
Chapter 3 Figure & Installation.....	5
3.1 Figure dimension.....	5
3.2 Installation Dimension	6
Chapter 4 Display & key operation.....	9
4.1 Full display	9
4.2 Status query.....	10
4.3 Key.....	10
4.4 Display Interface	10
4.5 Data setting.....	12
Chapter 5 Measurement	14
5.1 Real time basic electric parameter.....	14
5.2 Power Parameter	15
5.3 Data setting alarm	15
Chapter 6 Communication.....	17
6.1	17
6.2Communication Protocol.....	17
6.4 Communication Parameter	17
Chapter 7 Technical information.....	18
Chapter 8 Appendix	19
8.1 Terminal Definition.....	19
8.2 Typical connection wiring.....	20



Chapter 1 General Information

SPM20 CMS is a monitoring system especially to the power terminal by its micro distributed multi-circuit monitoring unit. It consists the measurement module and control module, and these two modules is connected by the PLbus general line which is also researched by Pilot, and the connector plug is by the standard RJ12 which can simplify the installation on site.

SPM20 is suitable to Power distribution cabinet and switch cabinet of the Low-voltage distribution system less than AC 220V (phase voltage) , and support to single phase two wires and three-phase four-wires system. One monitoring unit can support 30pcs measurement modules at most, and can monitor 10 three-phase circuits or 30 single phase circuits, and have the measurement and metering function to the general data of the three-phase branch (general power, total electric-energy). Its current measurement is in maximum 63A, can satisfy the different application on site.

The micro distribution multi-circuit measurement unit can be for multiple installation, and the controller conforms to DIN35 rail install, and backboard screw fixation install; There are the closed in line installation and opening buckle mounting for the option as required. The connection between the measurement unit and controller is by the standard RJ12 port, can make the wiring arrangement easy on site.

The Function realized as follows :

◆ Real-time data measurement

- 1/3 phase voltage
- 1/3 phase current
- Active power
- Reactive power
- Apparent power
- Power factor
- Frequency

◆ Metering

- Active energy
- Reactive energy

◆ Alarm

- Under voltage
- Over voltage
- Over current
- Module Fault

◆ Communication

- 1 RS485 communication , Modbus-RTU protocol



Chapter 2 Product Type

SPM20 consists 1 controller(SPM20-CTRL)and 30 measurement unit at most which has split core (SPM20-CTO) and solid core (SPM20-CTC) for the option or mixture use.

Model list :

SPM20-CTRL	AC: 3×220/380V , power supply from A phase voltage wire
SPM20-CTO	Rated current 10 (50) A , accuracy 2.0, hole 9.5mm
SPM20-CTC	Rated current 5 (63) A , accuracy 2.0, hole 8mm

The RJ12 among the measurement units by the daisy chain, the length are only by 6cm or 30cm for the site installation option, and the length of every measurement wire (PLbus) must not be more than 300cm.

Chapter 3 Figure & Installation

3.1 Figure dimension

unit : mm

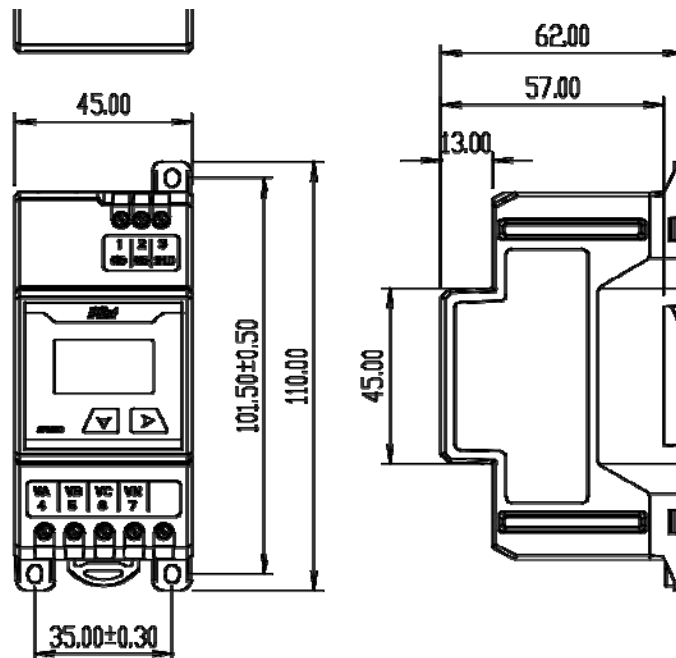

Figure 1 : controller dimension

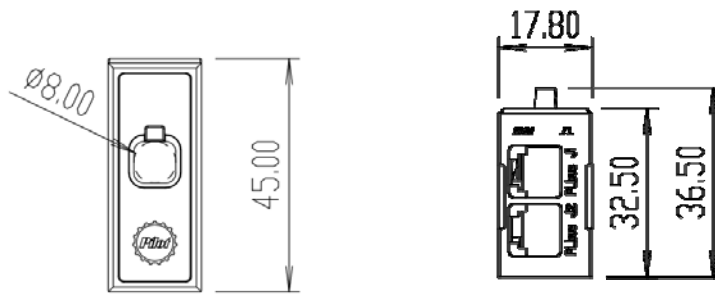

Figure 2: CTC Solid core measurement unit installation dimension

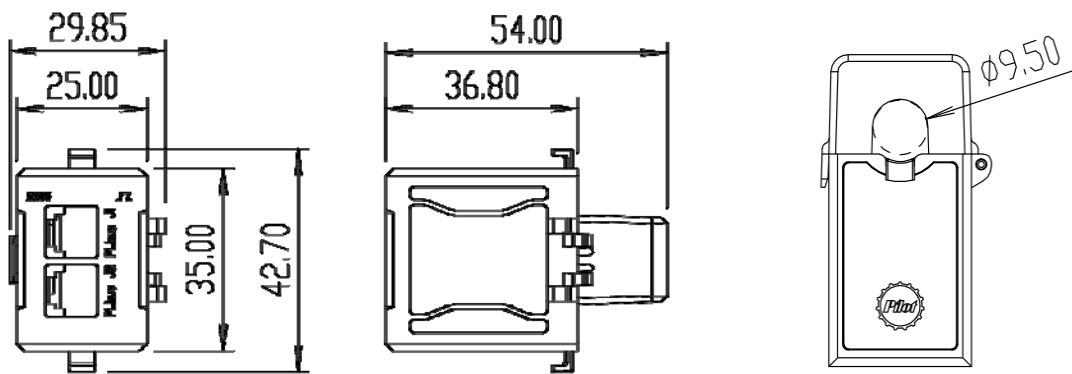

Figure 3: CTO split core buckle installation dimension

3.2 Installation Dimension

Unit : mm

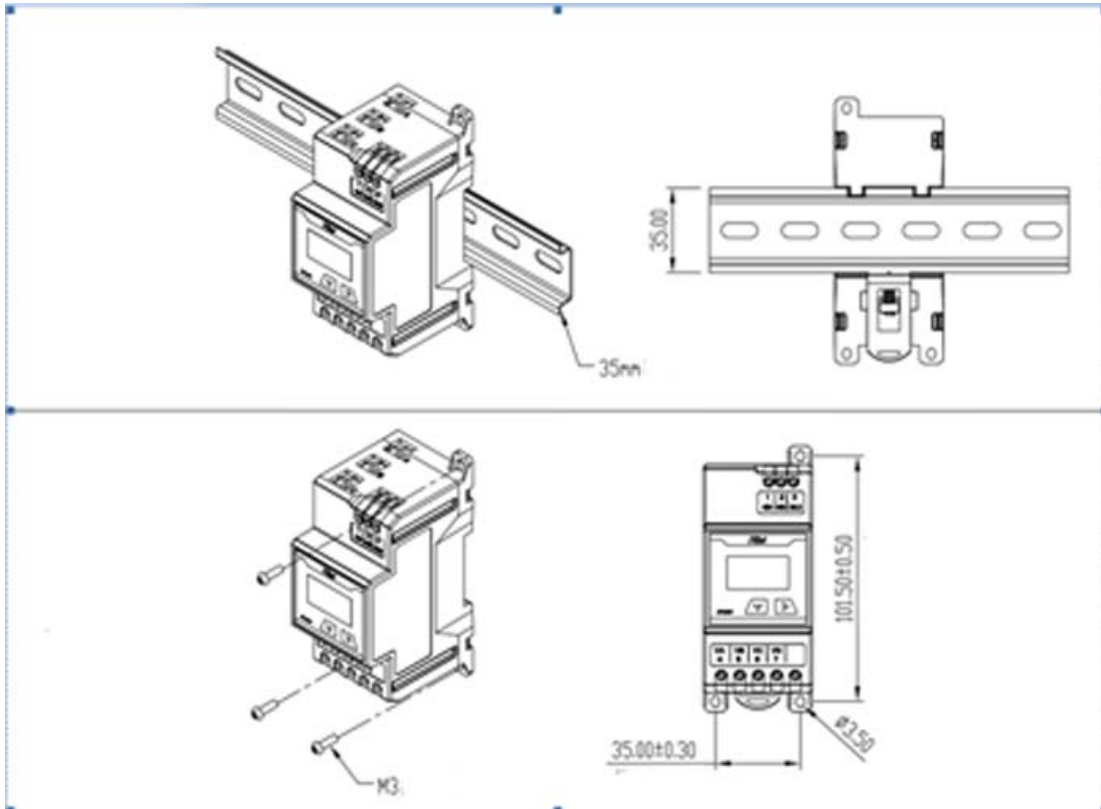

Figure 4: Controller installation

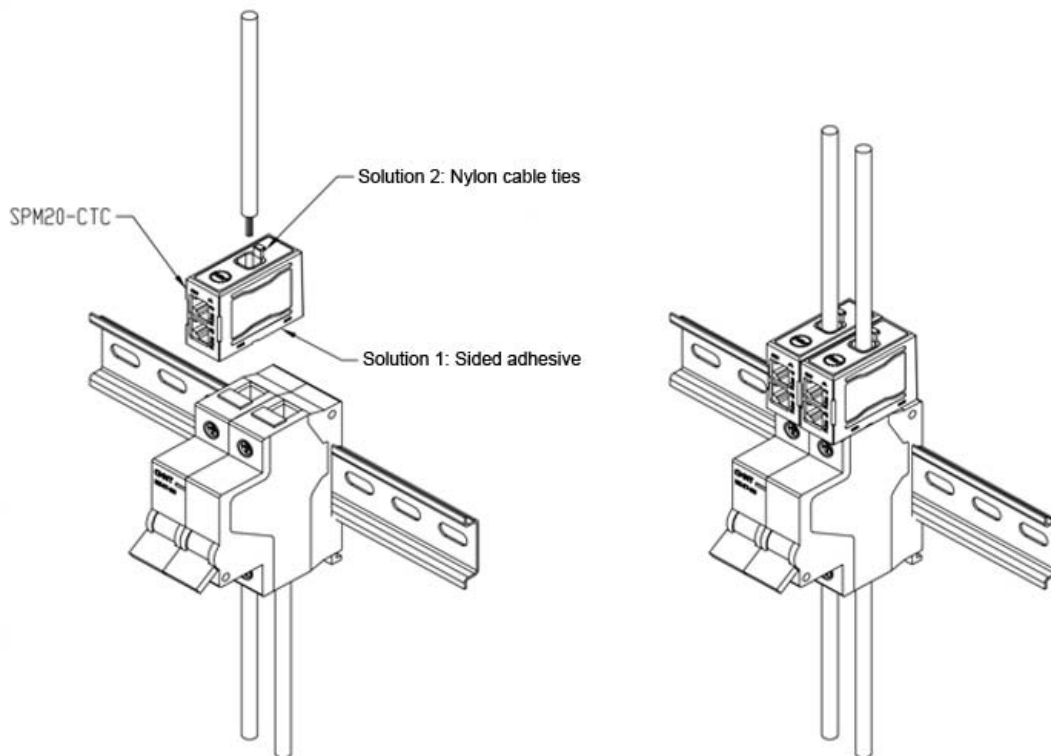

Figure 5: Solid core measurement unit installation

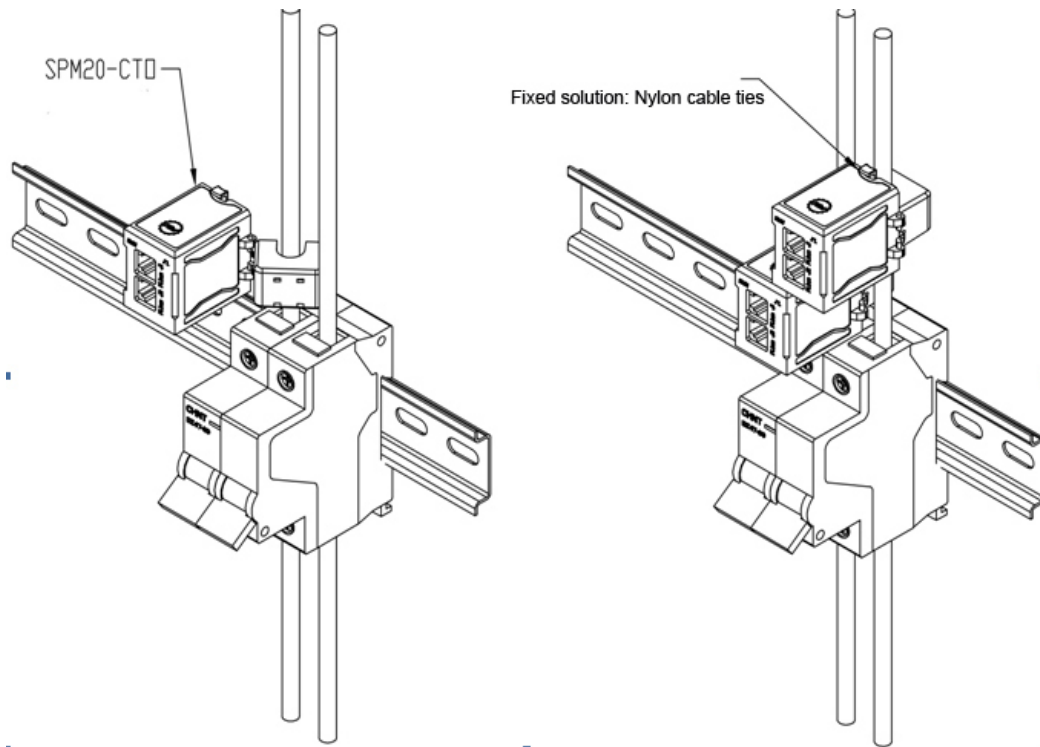

Figure 6: Split core measurement unit buckle installation

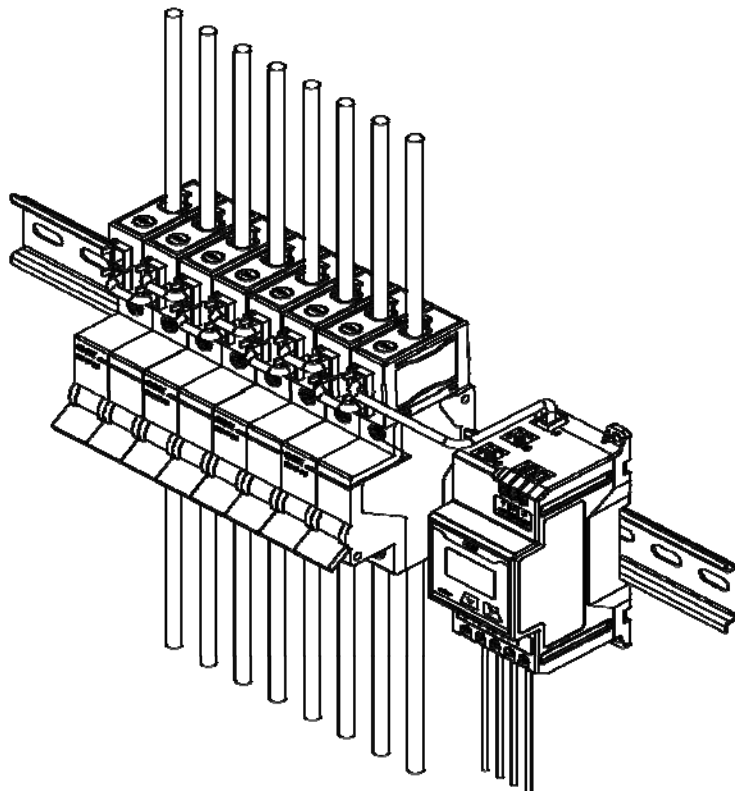

Figure 7: Solid core measurement unit installation

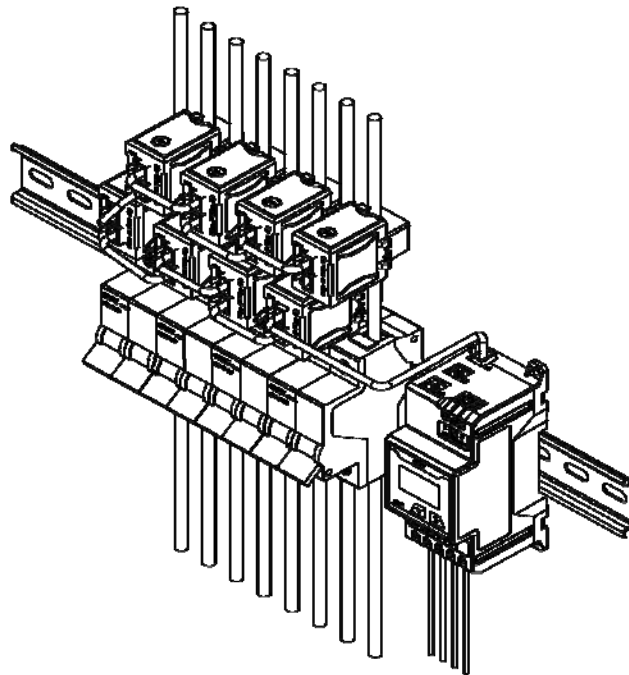

Figure 8: Split core measurement unit installation

Attention: Forbid hot plugging RJ12 connect to PLbus, because of the voltage passed safety range on RJ12 after SPM20 power on.

Chapter 4 Display & key operation

4.1 Full display

SPM20 has a LCD with resolution ratio of 128*64, which can realize multi-function menu change by the two key on LCD, and the menu prompt.

Remark : If no key operation within 60s, LCD backlight will be off, till the operation cause it lighting.

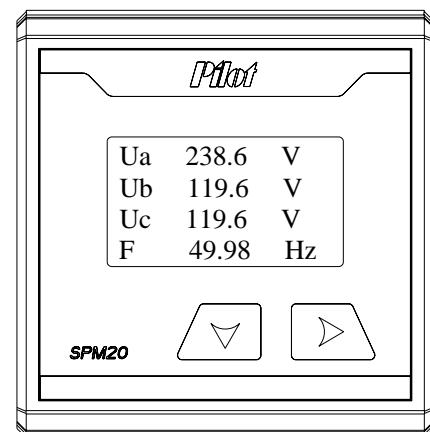



4.2 Status query

Indicator	Color	Display	Indication info
Status	Green	No light	Normal operation
		Light	Module on adding
		Flicker	Communicate to the controller, or flicker when the module energy page shown on this controller display.
Pulse	Red	Flicker	Energy pulse indication, pulse constant 1000

4.3 Key

Remark : The same key has different function on different interface.

 ALT in the same level menu

 Return / enter

4.4 Display Interface



Data display

energy : energy query

alarm : alarm query

info : meter info query

- energy query : Press any key on main page to enter into energy query page, and to show active energy of every monitoring module page by page; to show the total active energy of every 3P3W in 3P3W connection mode.

Press  to check the energy data of every circuit one by one, and press  to return to home page.

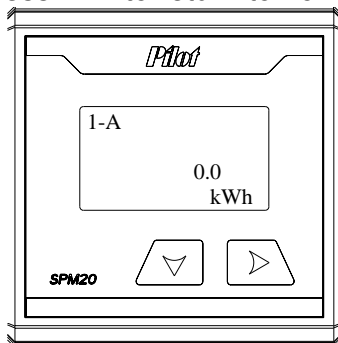

- Over voltage alarm: press  to enter into "voltage" alarm page as follows , B phase in alarm by its overvoltage.

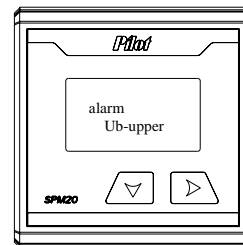

- Under voltage alarm: press  to enter into "voltage" alarm page as follows , A phase in alarm below lower limitation.

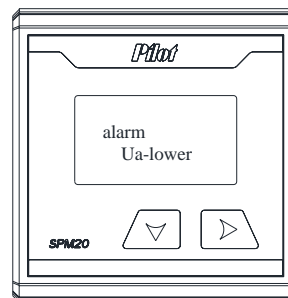

2. Alarm: Press  to enter into alarm interface, as follow:

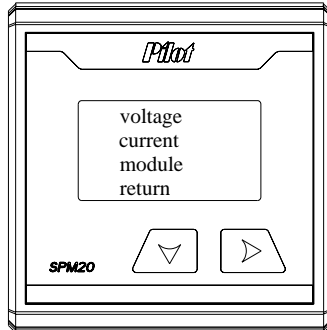

④ Module fault alarm: press  to enter into " module" alarm page as follows: module 1 in alarm of missing.

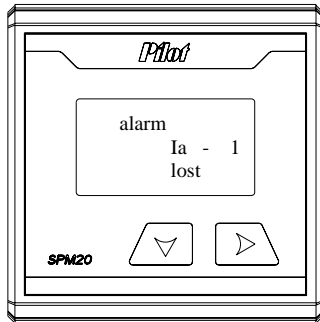

5. No alarm interface as follows:

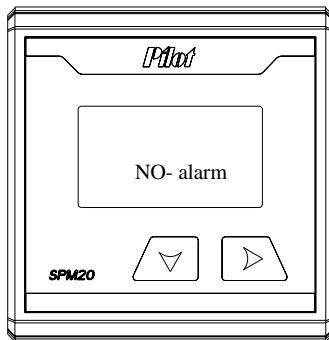

③ Over current alarm: press  to enter into "current"alarm page as follows: the circuit 1, A phase current in alarm surpass the upper limit.

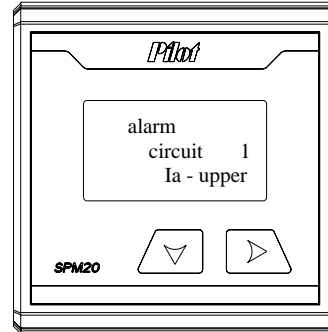

3. Meter info check: this page shows the wire connection mode, the communication port, and the configured module quantity and meter version, without password.

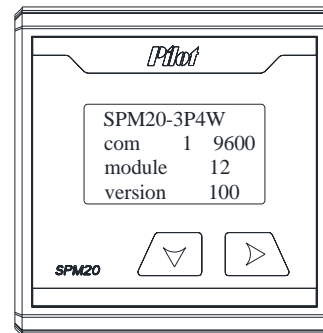

4.5 Data setting

■ Meter program

SPM20 can set data program :

Program item
CT module set
Controller communication

The different meter configured has the different items, or nothing. So the user should operate by according to the meter configuration :

1. Controller communication:

press  to enter into the communication interface, to set the communication address and baud rate as follows, address range: 1~247 ,

Baud rate range : 4800 、 9600、 19200

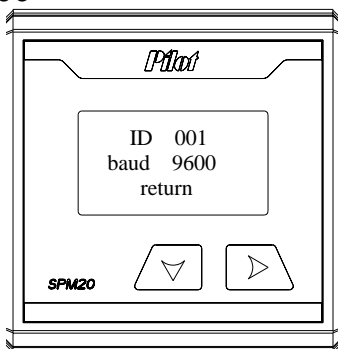

2. CT module set : add CT、 remove CT、 clear all CT , as follows :

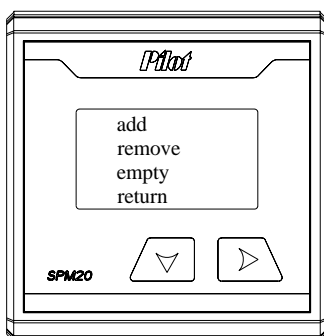

① Add CT: press  to be in "add" as follows: add CT 1.

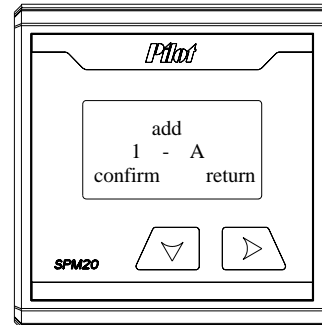

② Remove a CT: press  to be in "remove" as follows: remove CT 1

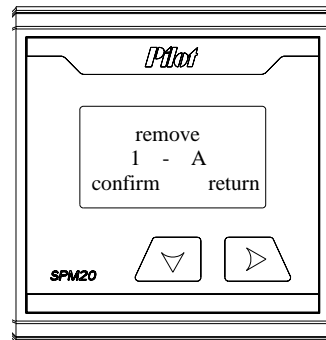

③ Clear all CT: Press  to be in "empty" as follows: clear all CTs

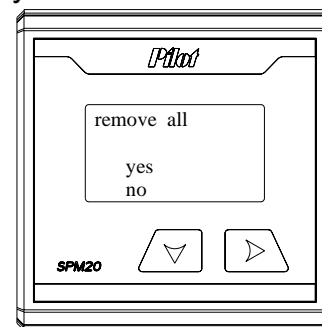

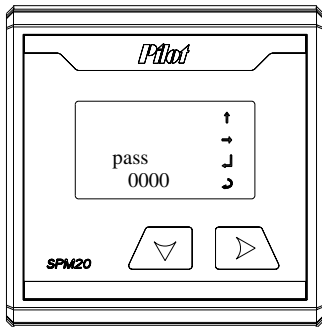

3. password : press  to be in password interface.
As follows:





Operation: typical example

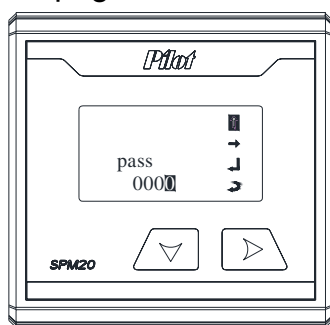

Suppose the meter rate current input 5A ,in 3P3W mode ,no any CT module connection on site, and the communication address 100 , initial password is 1 , now to add 1-A CT module as follows :

- 1、 press  to be in “set” interface, continue to press  to pop up the “password” page.



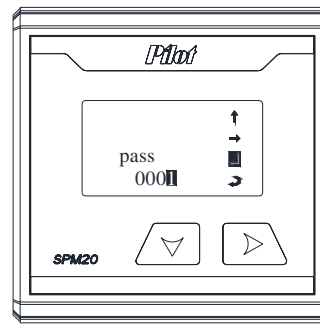

2. the present password unit digit flicker, press  to change the units digit as 1. And no change for the decade as it is 0, (initial password is 01) . The change accomplish as follows, press  to confirm.

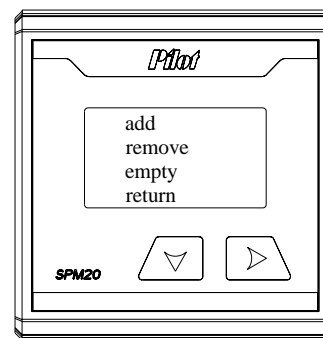

Password OK, press  to select module , press  to enter into the module interface



Press  to enter into “add” interface , press  to change the module address as follows :

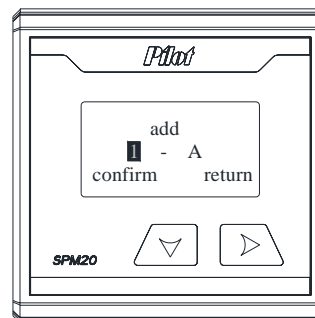

Press the button of the adding module, when the red light on, select “confirm” and press , then the red light off, means adding 1-A OK as follows :

■ **Attentions**

- 1、 when adding CT module, it must press the button of the module need to be added firstly, only after the left red light on, it could press“confirm”.
- 2、 Long press the module button more than 10s, to recover the module address to the default 1.
- 3、 Invalid by adding the repeat address
- 4、 it can distinguish the monitoring module address by checking the energy data. example : when check 1-A energy data , then the left red lamp light on of the 1-A module .
- 5、 when the set data invalid, the setting is void , so recover the original data ;
- 6、 for other customized function, no explanation in this manual !

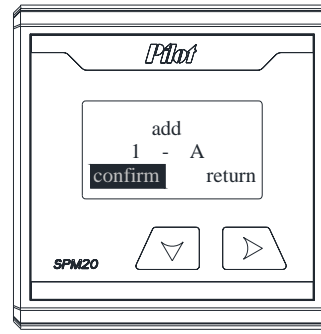

By the same way , other data modification is by the same procedure

Chapter 5 Measurement

5.1 Real time basic electric parameter

Real time reading	Measurement range
Current	
CTC solid core threading install	0 ~ 63A
CTO split core buckle install	0~ 50A
Voltage	
Wire – wire	0 ~ 460V
Wire – neutral wire	0 ~ 265V



Active/Reactive/Apparent Power	
Each phase	0 ~ ± 14KW/var/VA
Sum	0 ~ ± 42KW/var/VA
Power Factor	
Each phase	0 ~ +1.000
Sum	0 ~ +1.000
Frequency	
45 ~ 55Hz	45 ~ 55Hz

5.1.1 Voltage

SPM20 phase voltage range is 220V to which the user should pay attention, for prevent from the circuits inside saturation which could make the measurement not correct.

Suggestion : It should clear away the power energy, for reopening the energy accumulation, just after the wire connection mode.

5.1.2 Current

SPM20 current needs to be measured by monitoring module, with CTC (solid core threading install) and CTO (split core buckle install) for the application option. CTC rated current 5 (63A), can measure the circuit with the maximum 63A ; CTO rated current 10 (50A), can measure the circuit with the maximum 50A.

The user should pay attention to the current range of circuits in course of the design, to prevent from the circuit saturation which cause the incorrect measurement.

5.2 Power Parameter

SPM20 active/reactive, input/output electrical degree, the maximum accumulation is till to 99999999.9, by showing one decimal place; And will automatically reverse when the accumulation is to the maximum value.

5.3 Data setting alarm

SPM20 have custom data setting alarm system, for the electrical parameter monitoring by according to the set. When there is some alarm event, it could be changed to the alarm interface, for the alarm events checking and the reading of alarm types by the communication; after the alarm event removed, the "ALARM" light is off, and the alarm interface appear "NO-alarm".



Setting Alarm Subject table:

Alarm Subject	Alarm Active	Notice
Voltage upper limit	The Maxim primary voltage value in three phase > setting voltage upper limit value (3P4W, phase voltage value)	Active value = 0 means close alarm
Voltage lower limit	The Minimum primary voltage value in three phase more than 110V < setting voltage lower limit value	Active value = 0 means close alarm
Current lower limit	The Maxim primary current value in three phase > setting current upper limit value	Active value = 0 means close alarm

5.3.1 Alarm Output

When alarm happened, change to the page of alarm notice can check alarm type, press return key  will return to current interface. Alarm can also be checked by RS485 communication, after alarm disappeared, on the page of alarm will display “No-Alarm”



Chapter 6 Communication

6.1

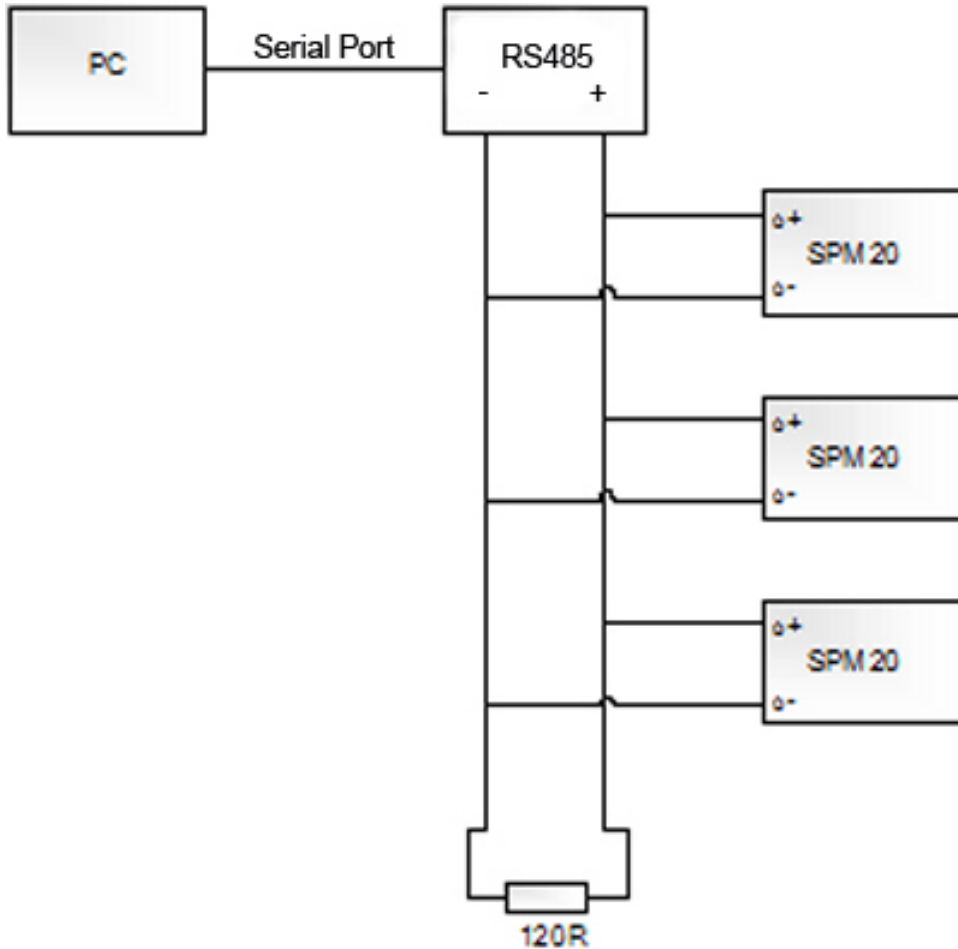

6.2 Communication Protocol

Please refer to SPM20 communication protocol manual

6.4 Communication Parameter

SPM20 communication parameter:

- ◇ Meter ID: Each SPM20 with unique ID number, free change by user
- ◇ Baud Rate: 4800, 9600, 19200 for choose



Chapter 7 Technical information

Parameters		Range	
Rated parameter	Rated power supply	Power supply from phase A voltage	
	Rated input current (CTC)	5 (63) A	
	Rated input current (CTO)	10 (50) A	
	Rated input voltage	AC 3P4W 3×220/380V , Range: 40%-150% , 45Hz~65Hz	
	Parameter	Range	Accuracy
Accuracy	Voltage	40%~120%	0.5%
	Current	1%~120%	0.5%
	PF	-1~1	1.0%
	Active Energy (CTC)	0~99999999.9	1%
	Active Energy (CTO)	0~99999999.9	2%
	Reactive Energy	0~99999999.9	2%
	Active Power	Single Phase : 0 ~ ±14 kW/var/VA Total :0 ~±42kW/var/VA	1.0%
	Reactive Power		2.0%
	Parameter	Performance	
	Power Loss	≤ 5W/10VA	
Temperature	Normal working	-20°C ~ +55°C	
	Limit operating temperature	-25°C ~ +75°C	
	Storage temperature	-30°C ~ +80°C	
	Humidity	Less than 95%	
Insulation performance	Power frequency withstand voltage	2000VAC	
	Insulation resistance	≥ 100MΩ	
	Impulse voltage	6000V	
IP	Total	IP20	
	Item	Standard	Class
	Electrostatic Discharge Immunity	GB/T17626.2-2006 (IEC61000-4-2:2001)	Class 4
	Radio frequency electromagnetic field radiation immunity	GB/T17626.3-2006 (IEC61000-4-3:2002)	Class 4
	Electrical Fast	GB/T17626.4-2008	Class 4



Electricity magnetic	Transient Burst Immunity	(IEC61000-4-4:2006)	
	Surge (shock) immunity	GB/T17626.5-2008 (IEC61000-4-5:2005)	Class 4
	Immunity to conducted disturbances induced by RF field	GB/T17626.6-2008 (IEC61000-4-6:2006)	Class 3
	Electromagnetic emission limits	GB 9254-2008 (CISPR22 : 2006)	Pass
	Voltage sag, short interrupt immunity	GB/T17626.11-2008 (IEC61000-4-11:2004)	Pass
	Power frequency withstand voltage	GB/T 17215.211-2006	

Chapter 8 Appendix

8.1 Terminal Definition

Item	Definition	Illustration	Item	Definition	Illustration
1	485+	RS485+	2	485-	RS485-
3	SHLD	RS485 Shield	4	VA	A phase
5	VB	B phase	6	VC	C phase
7	VN	Neutral	8	NC	Null
9	PLbusA	A phase measuring module port	10	PLbusB	B phase measuring module port
11	PLbusC	C phase measuring module port			

Measuring module (CTO&CTC)

Item	Definition	Illustration	Item	Definition	Illustration
1	J1	Measuring BUS port 1	2	J2	Measuring BUS port 2



8.2 Typical connection wiring

- Single phase two wire system

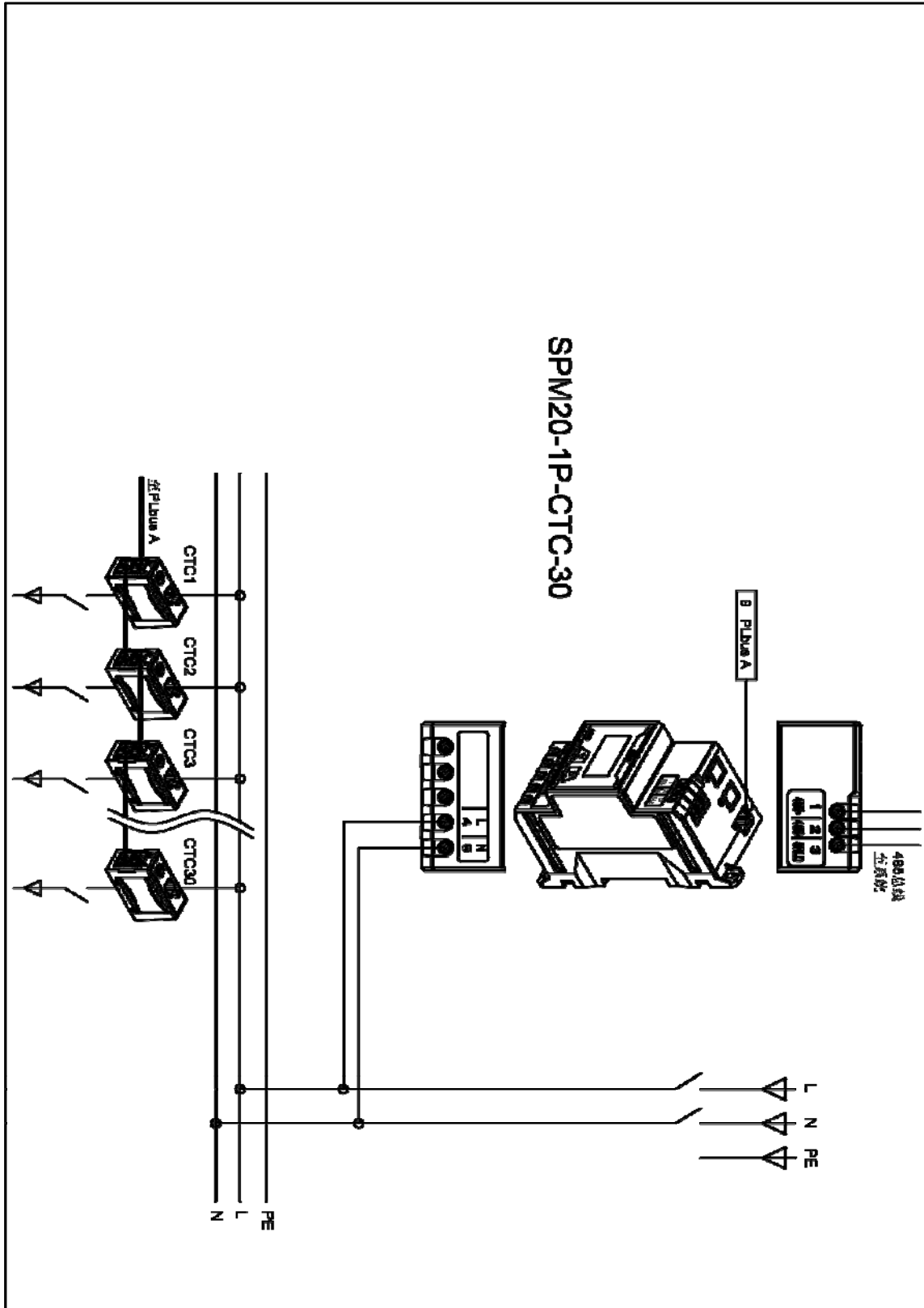



■3P4W system

