



HFS-25 Flow Switch

The paddle type HFS-25 flow switch is used for on/off indication of flow and pump operation proving in water pipes or pipes carrying other non-hazardous liquids which are suitable for use with the brass or phosphor-bronze components or the flow switch.

Because the HFS-25 features SPDT contacts it may be used to indicate flow (n/o) or no-flow (n/c) by wiring to the applicable pair of contacts.

Mounting

- Mount in to tee junction or welding sleeve
 - 5 x pipe diameter straight pipe length either side of the flow switch
 - May be mounted outdoors in horizontal pipe with housing upwards and a suitable cable entry gland is used to protect against water ingress
 - Additional water shielding protection should be provided in situations where the housing may be subjected to water jets under pressure such as with a hose
-

Switch Adjustment

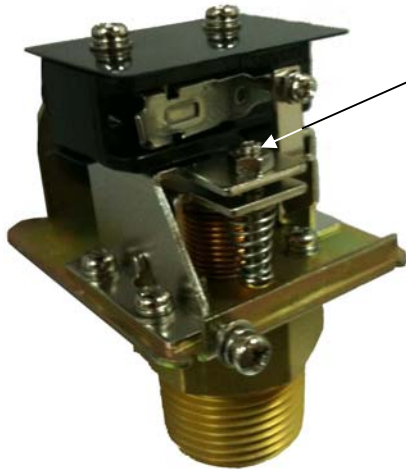

Switching sensitivity may be adjusted with the spring tension screw.

- Loosen the locknut
- Adjust screw clockwise to reduce spring tension (less water flow to operate the switch)
- Adjust screw anti-clockwise to increase spring tension (more water flow to operate the switch)
- Tighten the locknut

Paddle Length Selection

Three paddles are supplied for use in pipes up to DN150. The stated flow rates for operation are average values based on factory adjustment. Actual switch point may vary in practice.

Pipe Size	DN50	DN100	DN150
Flow (l/s)	0.575	1.25	2.5
Paddle Length	1"	2"	3"

Connections

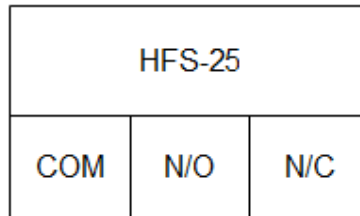

Caution



The power supply must be switched off before carrying out any alterations or maintenance



Only suitably qualified personnel should undertake any maintenance of the device



Observe local regulations with regard wiring and circuit protection

Dimensions

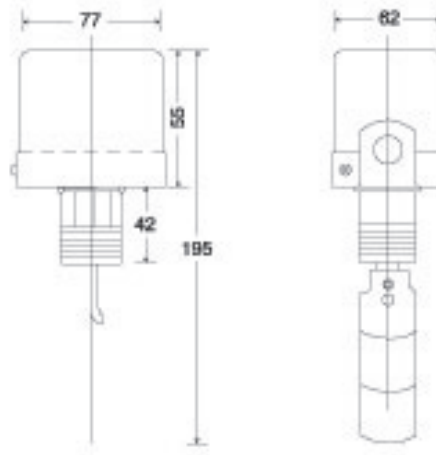

Technical Data

Switch Contacts:	SPDT, 15Amp, 250Vac
Operating Pressure:	PN 10
Ambient Operating Temperature:	0...60 °C
Maximum Liquid Temperature:	100 °C
Pipe Connection:	G 1 1/4"
Protection Class:	IP52 (horizontal pipe, housing vertical)
Conformity & approvals:	