



## HEMF Electromagnetic Flow Meter

Electromagnetic flow meters are widely used due to minimal flow obstruction, cost-effectiveness and accurate measurement. Electromagnetic flow meters have no moving parts to wear down, reducing the need for maintenance or replacement. We offer flowmeters with a range of liners, electrodes, and sizes, which can meet various conductive liquids.

- Wide range of nominal diameters (DN3-3000)
- Independent of pressure, temperature, density and viscosity
- No moving parts, maintenance-free
- Automatic power failure recording function (optional)
- Built-in grounding electrodes
- Bi-directional flow measurement
- Self-diagnosis function, empty pipe alarm, exciting alarm
- Support data record / bluetooth / wireless communication

## Industries

- Effluent Treatment Plant

- Sewage Treatment Plant Water Supply Scheme

- Steel & Aluminum Industries

- Food & Drug Industries

- Chemical & Fertilizer Industries

- Dairy Industries

- Sugar Industries

- Textile Processing Industries

## Applications

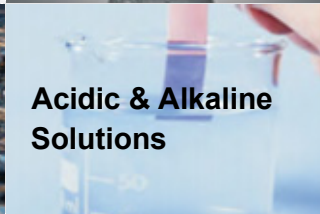
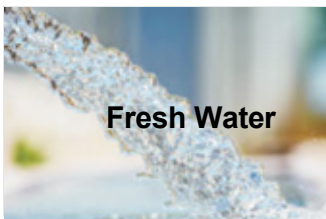



## Technical Data

Size	DN3-DN3000mm (1/8"-120")	
Accuracy	±0.5% of reading at flow velocity ≥ 0.5m/s, ±0.2% optional at flow velocity ≥ 0.5m/s	
Velocity	0.1~15 m/s	
Repeatability	≤0.17%	
Structure	Compact / remote, cable length 10m standard, 100m max	
Conductivity	> 5 μS/cm, demineralized water > 20 μS/cm	
Protection Grade	Transmitter: IP65 standard, IP67 optional Sensor: IP65 standard, IP68 (submersible, only available for remote type)	
Electrode	SS316L, Hastelloy C, Hastelloy B, Titanium, Tantalum, Platinum-iridium	
Power Supply	85~250 VAC (50/60 Hz), 20~36 VDC	
Power Consumption	<20W	
Signal Output	Analog	4~20mA ( load resistor 0~750Ω)
	Frequency	Forward & reverse flow output with a frequency range of 1~5000Hz
	Alarm	Two isolated open collector transistor (OCT) outputs for alarm signals
Communication	RS485 MODBUS RTU standard, HART, GPRS, PROFIBUS optional	
Display	LCD Display, 128X128mm, three lines, 4 buttons	
Ambient Temperature	-20°C~60°C	
Fluid Temperature	Compact: -20°C~80°C, Remote: -20°C~120°C	
Liner Material	PTFE (-20°C~150°C, DN15-DN1600)	
	FEP (-20°C~120°C, DN3-DN1800)	
	PFA (-20°C~160°C, DN3-DN800)	
	Polyurethane (-10°C~60°C, DN40-DN1600)	
	Neoprene (-10°C~80°C, DN40-DN3000)	
	Hard Rubber (-10°C~80°C, DN 40-DN3000)	
	Ceramic (-20°C~180°C, DN15-DN200)	
Flange Standard	DIN, ANSI, JIS	
Sensor Material	Measuring tube: SS304	
	Flange & housing: carbon steel (standard), SS304 / SS316 optional	
Transmitter Material	Aluminium alloy with epoxy painting	
Nominal Pressure	PN10 / PN16 / PN25 / PN40	DIN
	10K / 20K / 30 K	JIS
	150# / 300# / 600#	ANSI
	High pressure 42 MPa / ANSI 2500# can be customized	
Display	Instantaneous flow, total flow, flow velocity	
Function	High and low alarm, exciting alarm, empty pipe alarm, self-diagnosis	
Totalizer	Three built-in totalizers: forward flow, reverse flow and net flow	
Display Unit	L/s, L/m, L/h, m³/s, m³/m, m³/h, UKG, USG, gal/s, gal/m, gal/h, kg/s, kg/m, kg/h, t/s, t/m, t/h	
Language	English, Chinese, Italian, Portuguese, French, Spanish, Korean	



# Transmitter

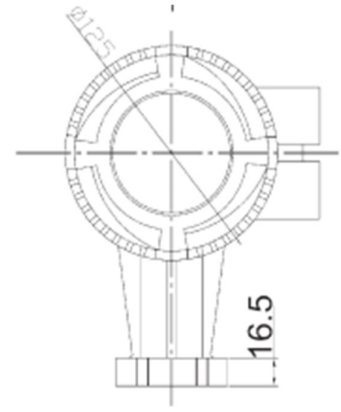
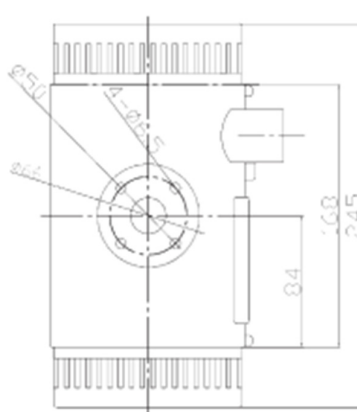

Compact Transmitter

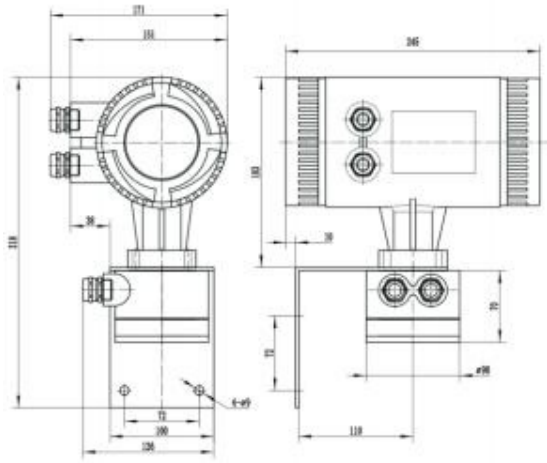
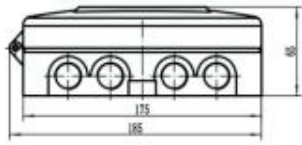
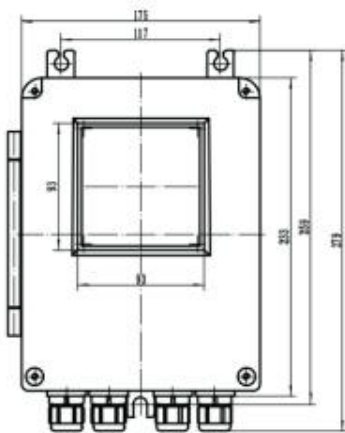
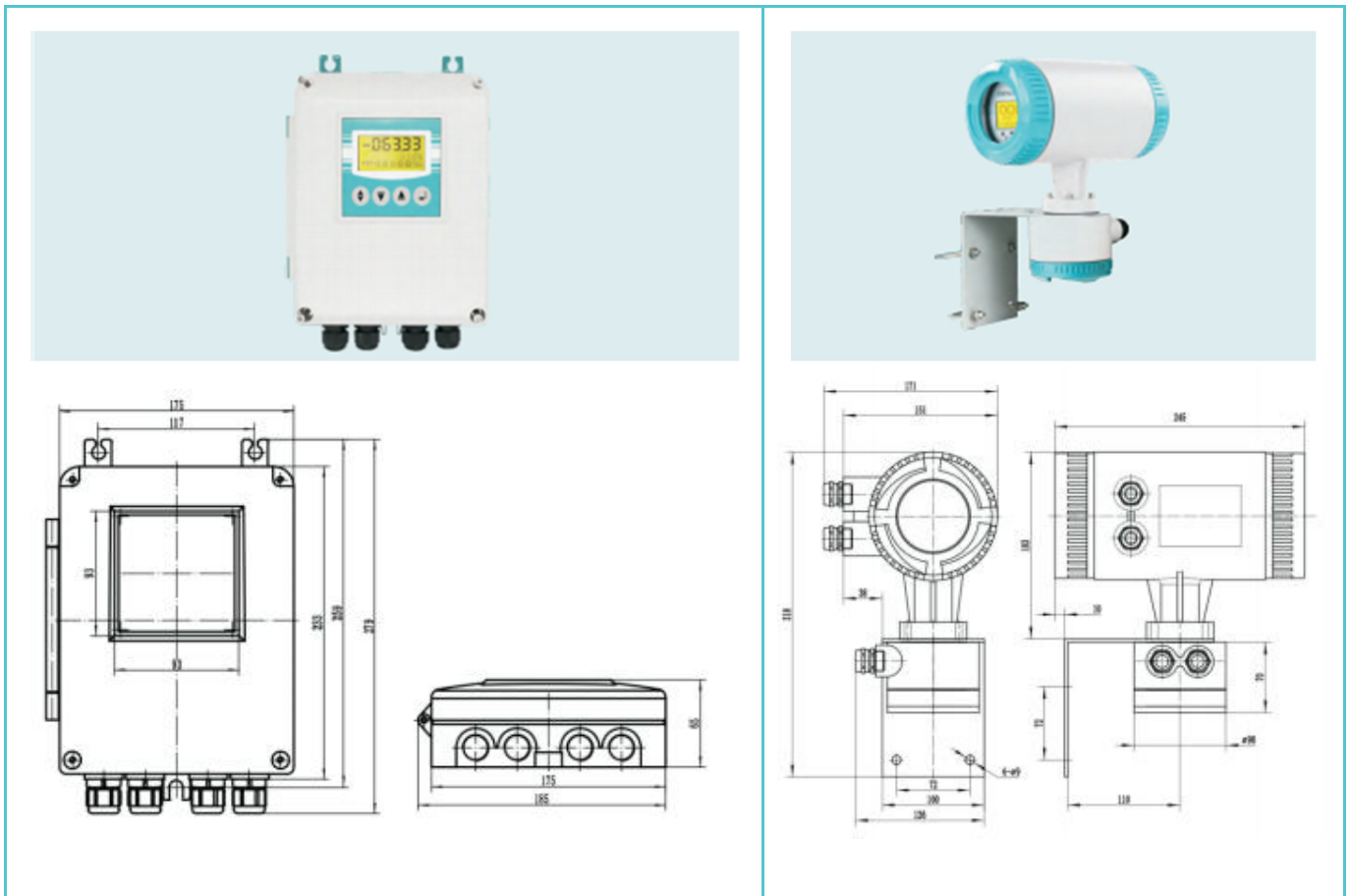

Remote Transmitter



## Dimensions

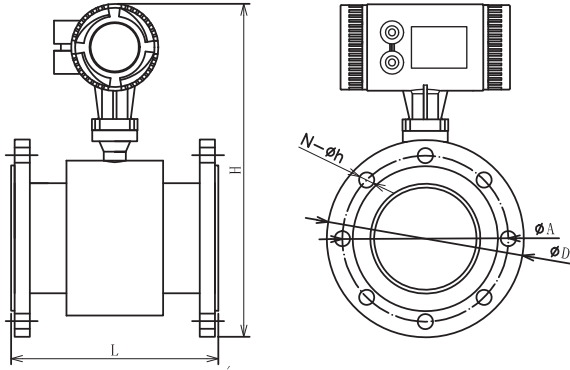

DN15-DN600 Compact Electromagnetic Flow Meter with DIN Drawing

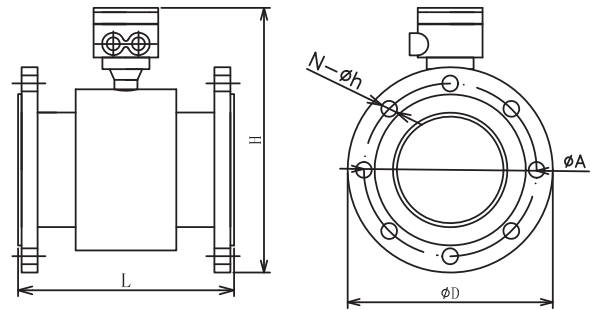

DN15-DN600 Remote Electromagnetic Flow Meter with DIN Drawing

Compact Mag Flow Meter Size						
Size	Nominal Pressure	L (mm)	φD (mm)	φA (mm)	H (mm)	N-φh (mm)
15	PN16	200	95	65	332	4-φ14
20		200	105	75	332	4-φ14
25		200	115	85	335	4-φ14
32		200	140	100	352	4-φ18
40		200	150	110	362	4-φ18
50		200	165	125	375	4-φ18
65		200	185	145	395	4-φ18
80		200	200	160	402	8-φ18
100		250	220	180	422	8-φ18
125		250	250	210	452	8-φ18
150		300	285	240	485	8-φ22
200		350	340	295	542	12-φ22
250		450	405	355	607	12-φ26
300		PN10	500	445	400	652
350	550		505	460	707	16-φ22
400	600		565	515	770	16-φ26
450	600		615	565	820	20-φ26
500	600		670	620	872	20-φ26
600	600		780	725	994	20-φ30

Remote Mag Flow Meter Size						
Size	Nominal Pressure	L (mm)	φD (mm)	φA (mm)	H (mm)	N-φh (mm)
15	PN16	200	95	65	220	4-φ14
20		200	105	75	220	4-φ14
25		200	115	85	223	4-φ14
32		200	140	100	240	4-φ18
40		200	150	110	250	4-φ18
50		200	165	125	263	4-φ18
65		200	185	145	283	4-φ18
80		200	200	160	290	8-φ18
100		250	220	180	310	8-φ18
125		250	250	210	340	8-φ18
150		300	285	240	373	8-φ22
200		350	340	295	430	12-φ22
250		450	405	355	495	12-φ26
300		PN10	500	445	400	540
350	550		505	460	595	16-φ22
400	600		565	515	658	16-φ26
450	600		615	565	708	20-φ26
500	600		670	620	760	20-φ26
600	600		780	725	882	20-φ30



## Dimensions

Size is from 1/2"-24", other sizes can be provided upon request.

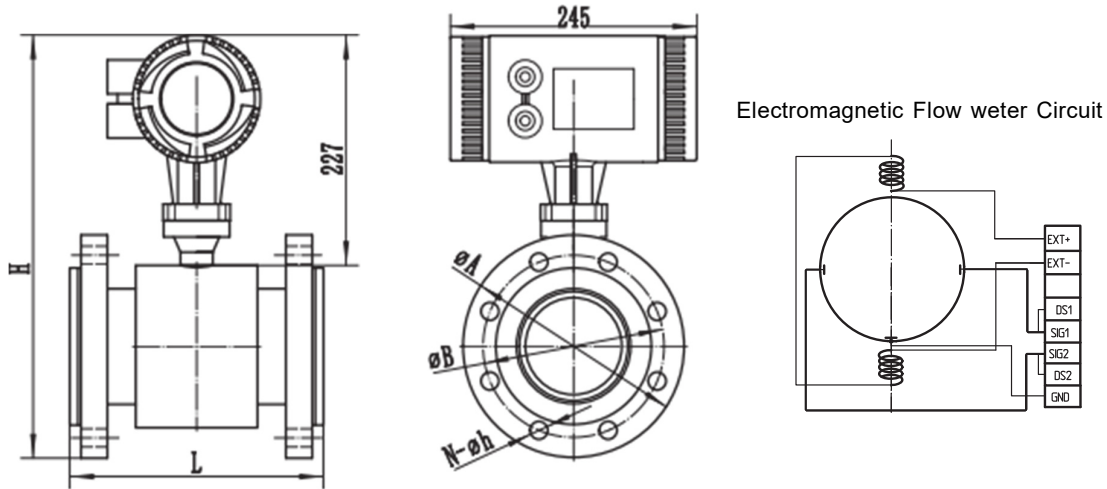

1/2"-24" Compact Electromagnetic Flow Meter with ANSI 150# Drawing

Size	Flange Standard	Pressure Rate	H (mm)	L (mm)	φA (mm)	φB (mm)	N (mm)	φh (mm)
1/2"	ANSI	150#	318	200	88.9	60.45	4	15.7
3/4"	ANSI	150#	323	200	98.6	69.85	4	15.7
1"	ANSI	150#	328	200	108	79.25	4	15.7
1¼"	ANSI	150#	333	200	117.3	88.9	4	15.7
1½"	ANSI	150#	343	200	127	98.6	4	15.7
2"	ANSI	150#	363	200	152.4	120.7	4	19.1
2½"	ANSI	150#	383	200	177.8	139.7	4	19.1
3"	ANSI	150#	398	200	190.5	152.4	4	19.1
4"	ANSI	150#	426	250	228.6	190.5	8	19.1
5"	ANSI	150#	449	250	254	215.9	8	22.4
6"	ANSI	150#	477	300	279.4	241.3	8	22.4
8"	ANSI	150#	538	350	342.9	298.5	8	22.4
10"	ANSI	150#	613	450	406.4	362	12	25.4
12"	ANSI	150#	678	500	482.6	431.8	12	25.4
14"	ANSI	150#	728	550	533.4	476.3	12	28.4
16"	ANSI	150#	784	600	596.9	539.8	16	28.4
18"	ANSI	150#	830	600	635	577.9	16	31.75
20"	ANSI	150#	887	600	698.5	635	20	31.75
24"	ANSI	150#	999	600	812.8	749.3	20	35.1



## Dimensions

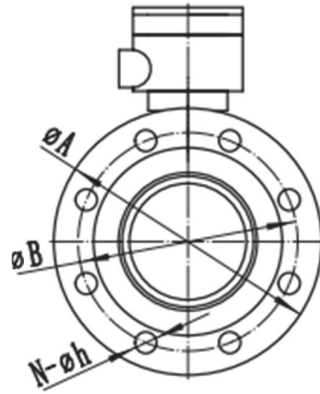
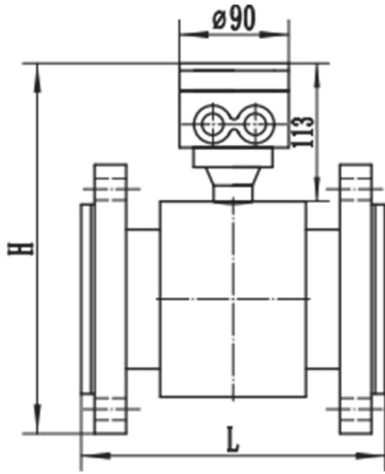

Electromagnetic Flowmeter Circuit

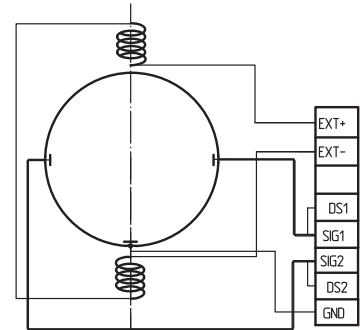

1/2"-24" Remote Electromagnetic Flow Meter with ANSI 150# Drawing

Size	Flange Standard	Pressure Rate	H (mm)	L (mm)	$\phi A$ (mm)	$\phi B$ (mm)	N (mm)	$\phi h$ (mm)
1/2"	ANSI	150#	204	200	88.9	60.45	4	15.7
3/4"	ANSI	150#	209	200	98.6	69.85	4	15.7
1"	ANSI	150#	214	200	108	79.25	4	15.7
1 1/4"	ANSI	150#	219	200	117.3	88.9	4	15.7
1 1/2"	ANSI	150#	229	200	127	98.6	4	15.7
2"	ANSI	150#	249	200	152.4	120.7	4	19.1
2 1/2"	ANSI	150#	269	200	177.8	139.7	4	19.1
3"	ANSI	150#	284	200	190.5	152.4	4	19.1
4"	ANSI	150#	312	250	228.6	190.5	8	19.1
5"	ANSI	150#	335	250	254	215.9	8	22.4
6"	ANSI	150#	363	300	279.4	241.3	8	22.4
8"	ANSI	150#	424	350	342.9	298.5	8	22.4
10"	ANSI	150#	499	450	406.4	362	12	25.4
12"	ANSI	150#	562	500	482.6	431.8	12	25.4
14"	ANSI	150#	614	550	533.4	476.3	12	28.4
16"	ANSI	150#	670	600	596.9	539.8	16	28.4
18"	ANSI	150#	716	600	635	577.9	16	31.75
20"	ANSI	150#	773	600	698.5	635	20	31.75
24"	ANSI	150#	885	600	812.8	749.3	20	35.1



## Main Performance of Electrode Material

Electrode Material	Application
SS316L	Applicable to industrial and municipal water, wastewater and low corrosive mediums. Widely used in petroleum, chemical industries.
Hastelloy B	Strong resistance to hydrochloric acids below the boiling point. Resist against oxidable acids, alkali and non-oxidable salts, like vitriol, phosphate, hydrofluoric acids and organic acids.
Hastelloy C	Exceptional resistance to strong solutions of oxidizing salts and acids, like Fe <sup>+++</sup> , Cu <sup>++</sup> , Nitric acids, mixed acids.
Titanium	Titanium can withstand corrosive mediums such as seawater, chloride salt solutions, hypochlorite salts, oxidable acids (including fuming nitric acids), organic acids, and alkali. Not resistant to high purity reducing acids such as sulphuric acids, hydrochloric acids.
Tantalum	Highly resistant to corrosive mediums. Applicable to all chemical mediums except Hydrofluoric Acids, Oleum and Alkali.
Platinum-iridium	Applicable to all chemical mediums except for Ammonium salts and Fortis.

## Main Performance of Liner Material

PTFE	Best chemical resistance, withstand boiling hydrochloric acid, sulfuric acid, nitric acid, alkali and a variety of organic solvents. Poor wear resistance and poor adhesion.
PFA	Highly resistant to chemicals. Performance well under vacuum pressure condition.
Neoprene	Excellent elasticity, good abrasion resistance. Withstand the corrosion of low-concentration acid, alkali, salt and other media. Not resistant to corrosion by oxidizing medium.
Polyurethane	Strong abrasion resistant, applicable for slurries and muds. Poor corrosion resistance, can't be used for corrosive medium.
Hard Rubber	Withstand the corrosion of hydrochloric acid, acetic acid, oxalic acid, ammonia water, phosphoric acid and 50% sulfuric acid, sodium hydroxide, potassium hydroxide. Use for general acid, alkali, and salt solutions, not resistant to the corrosion of strong oxidants.
Ceramic	Withstands high temperature, corrosion and wear Smooth inner Totally vacuum resistant



## Selection Table

HEMF		x	x	x	x	x	x	x	x	x	x	x
Caliber size	DN3-DN3000 (1/8"-120")											
Structure	Compact		1									
	Remote		2									
	Compact with explosion proof		3									
	Remote with explosion proof		4									
Accuracy	±0.5%			1								
	±0.2%			2								
	Others			3								
Lining Material	PTFE				1							
	FEP				2							
	PFA				3							
	Neoprene				4							
	Polyurethane				5							
	Hard Rubber				6							
	Ceramic				7							
	Others				8							
Electrode Material	SS316L					1						
	Hastelloy B					2						
	Hastelloy C					3						
	Titanium					4						
	Tantalum					5						
	Platinum-iridium					6						
	Stainless steel covered with tungsten carbide					7						
	Others					8						
Sensor Material	Carbon steel						1					
	SS304						2					
	SS316						3					
Power Supply	20~36 VDC							G				
	85~265 VAC							E				
	9~36 VDC solar power							SD				
	Others							X				
Signal Output / Communication	4~20 mA + Pulse + RS485 MODBUS								A			
	4~20 mA + HART								B			
	4~20 mA + Profibus PA/DP								C			
	GPRS								D			
Flange Process Connection	DIN D10: PN10, D16: PN16, D25: PN25, D40: PN40									D**		
	ANSI A15: 150#, A30: 300#, A60: 600#									A**		
	JIS J10: 10K, J20: 20K, J30: 30K									J**		
	Others									O		
Protection Grade	IP65 Transmitter + IP65 sensor										1	
	IP65 Transmitter + IP68 sensor (remote)										2	
Transmitter	Square											A
	Round											B





## Flow Range Table

Size		Flow Range & Velocity Table							
mm	Inch	0.1 m/s	0.2 m/s	0.5 m/s	1 m/s	4 m/s	10 m/s	12 m/s	15 m/s
DN3	1/8"	0.003	0.005	0.013	0.025	0.102	0.254	0.305	0.382
DN6	1/4"	0.01	0.02	0.051	0.102	0.407	1.017	1.221	1.526
DN10	3/8"	0.028	0.057	0.141	0.283	1.13	2.826	3.391	4.239
DN15	1/2"	0.064	0.127	0.318	0.636	2.543	6.359	7.63	9.538
DN20	3/4"	0.113	0.226	0.565	1.13	4.522	11.304	13.56	16.956
DN25	1"	0.177	0.353	0.883	1.766	7.065	17.663	21.2	26.494
DN32	1¼"	0.289	0.579	1.447	2.894	11.575	28.938	34.73	43.407
DN40	1½"	0.452	0.904	2.261	4.522	18.086	45.216	54.26	67.824
DN50	2"	0.707	1.413	3.533	7.065	28.26	70.65	84.78	10.598
DN65	2½"	1.19	2.39	5.97	11.94	47.76	119.4	143.3	179.1
DN80	3"	1.81	3.62	9.04	18.09	72.35	180.86	217	271.3
DN100	4"	2.83	5.65	14.13	28.26	113.04	282.6	339.1	423.9
DN125	5"	4.42	8.83	22.08	44.16	176.63	441.56	529.9	662.34
DN150	6"	6.36	12.72	31.79	63.59	254.34	635.85	763	953.78
DN200	8"	11.3	22.61	56.52	113.04	452.16	1130.4	1356	1696
DN250	10"	17.66	35.33	88.31	176.53	706.5	1766.25	2120	2649
DN300	12"	25.43	50.87	127.2	254.34	1017	2543.4	3052	3815
DN350	14"	34.62	69.24	1731	3461.9	1385	3461.85	4154	5193
DN400	16"	45	90	2261	452	1809	4522	5426	6782
DN450	18"	57	114	2861	572	2289	5723	6867	8584
DN500	20"	71	141	3533	707	2826	7065	8478	10598
DN600	24"	102	203	5087	1017	4069	10174	12208	15260
DN700	28"	138	277	6924	1385	5539	13847	16617	20771
DN800	32"	181	362	9043	1809	7235	18086	21704	27130
DN900	36"	229	458	1145	2289	9156	22891	27469	34336
DN1000	40"	283	565	1413	2826	11304	28260	33912	42390
DN1200	48"	407	814	2035	4069	16278	40694	48833	61042
DN1400	56"	554	1108	2769	5539	22156	55390	66468	83084
DN1600	64"	723	1447	3617	7235	28938	72346	86815	108518
DN1800	72"	916	1831	4578	9156	36625	91562	109875	137344
DN2000	80"	1130	2261	5652	11304	45216	113040	135648	169560
DN2200	88"	1368	2736	6839	13678	54711	136778	164134	205168
DN2400	96"	1628	3256	8139	16278	65111	162778	195333	244166
DN2600	104"	1910	3821	9552	19104	76415	191038	229245	286556
DN2800	112"	2216	4431	11078	22156	88623	221558	265870	332338
DN3000	120"	2543	5087	12717	25434	101736	254340	305208	381510

Remark: Recommend flow velocity range 0.5 ~ 15 m/s