

PMAC770 Multifunction Power Meter

Installation & Operation Manual

V1.1





Danger and warning!

This device can be installed only by professionals.

The manufacturer shall not be held responsible for any accident caused by the failure to comply with the instructions in this manual.



Risks of electric shocks, burning, or explosion

- This device can be installed and maintained only by qualified people.
- Before operating the device, isolate the voltage input and power supply and short-circuit the secondary windings of all current transformers.
- Use appropriate voltage tester to make sure the voltage has been cut-off.
- Put all mechanical parts, doors, or covers in their original positions before energizing the device.
- Always supply the device with the correct working voltage during its operation.

Failure to take these preventive measures could cause damage to equipment or injuries to people.



Operating environment

- Operating temperature: $-10^{\circ}\text{C}\sim+55^{\circ}\text{C}$
- Storage temperature: $-40^{\circ}\text{C}\sim+70^{\circ}\text{C}$
- Relative humidity: 5%~95%, non-condensing
- Operating power supply: (Have 2 options, please check the label on the meter)
 - (1) 85Vac ~265Vac, 85Vdc ~265Vdc, 45-65Hz
 - (2) 100~420Vac, 100~400Vdc, 45~60Hz

CONTENTS

1. General Information.....	7
2. Order Information.....	9
3. Packing list.....	11
4. Figure and Terminals.....	12
4.1 Dimension.....	12
4.2 Installation.....	12
4.3 Terminals.....	13
5. Connection Mode and Wiring.....	20
6. Display and Key-press Operation.....	24
6.1 Display Instruction.....	24
6.2 Keys.....	25
6.3 Map of Display Data.....	26
7. Query Procedure.....	27
7.1 Initial Display.....	27
7.2 Voltage Value.....	28
7.3 Current Value.....	30
7.4 Frequency.....	31
7.5 Power Value.....	32
7.6 Energy.....	33
7.7 Harmonic.....	35
7.8 Demand.....	37
7.9 Analog Input (Optional).....	38

8. Setting.....	39
8.1 Instruction.....	39
8.2 Setting Site-map.....	41
8.3 METER—Meter Setting Menu.....	42
8.4 COM—Communication Setting Menu.....	44
8.5 CLEAR—Clearing Data Menu.....	44
8.6 RELAY—Relay Setting Menu.....	45
8.7 AO—Analog Output Setting Menu (Optional).....	46
8.8 LIMIT—Deviation Limit Setting Menu.....	46
8.9 ERROR.....	47
9. Measuring Function Description.....	48
9.1 Voltage.....	49
9.2 Current.....	50
9.3 Active power.....	51
9.4 Reactive power.....	51
9.5 Apparent power.....	51
9.6 Power factor.....	52
9.7 Frequency.....	53
9.8 Demand calculation.....	53
9.9 Phase sequence detect.....	54
10. Power Quality Analysis.....	56
10.1 General Description.....	57
10.2 THD.....	57
10.3 Harmonic Ratio for Voltage.....	57

10.4 Harmonic Ratio for Current.....	58
10.5 Voltage Crest Factor.....	58
10.6 Current K Factor.....	58
10.7 Harmonic Voltage RMS.....	59
10.8 Harmonic Current RMS.....	59
10.9 Harmonic Power RMS.....	59
10.10 Harmonic Energy RMS.....	59
10.11 Frequency Deviation.....	59
10.12 Voltage Deviation.....	60
10.13 Voltage Unbalance Rate.....	60
11. Energy and Multi-tariff Energy Statics.....	62
11.1 General Description.....	62
11.2 Active Energy.....	62
11.3 Reactive Energy.....	63
11.4 Multi-tariff Energy.....	63
11.5 History Energy.....	65
12. Record Function.....	65
12.1 General Description.....	65
12.2 SOE Event Log.....	65
12.3 Frequency Deviation Record.....	66
12.4 Voltage Deviation Record.....	66
12.5 Voltage Unbalance Record.....	67
12.6 Max. Demand Record.....	67
12.7 Max./ Min. Record.....	68

13. Setpoint Alarm.....	69
13.1 General Description.....	69
13.2 Setpoint Object.....	69
13.3 Alarm Condition.....	70
13.4 Alarm Output.....	70
13.5 Example.....	71
14. Auxiliary Function.....	72
14.1 Communication.....	72
14.1.1 Communication Medium.....	72
14.1.2 Communication Protocol.....	73
14.2 Status Input.....	73
14.3 Relay Output.....	74
14.4 4~20mA Analog Input (optional module).....	76
14.5 Pulse Output (optional module).....	76
14.6 Analog Output (optional module).....	76
14.7 Memory (optional module).....	79
15. Technical Specification.....	81
16. Maintenance and Trouble Shooting.....	85

1. General Information

PMAC770 Three Phase Multifunction Power Meter is designed for monitoring and displaying all kinds of electricity parameters. It's widely used in low voltage and medium voltage distribution/ automation system.

PMAC770 provide the main function as below:

- Real-time measuring data, true RMS
- All energy data (include real energy, multi-tariff energy, history energy, 1st ~13th harmonic energy).
- Power quality analysis
- Demand calculation
- Build-in clock and event log
- Over/ under limit alarm
- Phase sequence checking
- Modbus communication
- Digital input/ Digital output (DI/ DO)
- Analog input/ Analog output (AI/ AO, optional)
- 2 pulse output (optional) etc.

Measuring Function of PMAC770 Basic Unit (there are 3 class)	Basic class	Middle class	High class
Voltage, Current, Power (P, Q, S), Power factor, Energy (kwh, kvarh in 4 quadrant), Frequency, Demand, Max./ min. value (U, I, P, Q), Multi-tariff energy, Load rate One RS485 (Modbus-RTU), Real-time clock,	√	√	√
3 status input + 2 relay output Over / under limit alarm SOE event log	×	√	√
Voltage unbalance, THD, 31 st harmonic, Harmonic RMS(0~31 st), Harmonic energy (1~13 th), Voltage crest factor, Current K factor, Voltage deviation, Frequency deviation Record for voltage/ frequency deviation, Voltage unbalance record	×	×	√

2. Order Information

Model No. PMAC770—① - ② - ③ - ④ - ⑤	
① Function of basic unit	
N	Basic class
Z	Middle class
E	High class
② Optional Module (multiple choice, one meter can add no more than 3 modules. One meter can add 2 pcs of Module S, but only 1pcs of other modules.)	
S	DI module: 4 Digital Input (wet contact),
R	DO module: 2 Relay output
C	RS485 module: the 2 nd RS485 port (Modbus-RTU protocol)
P	Profibus module: Profibus protocol
AO	AO module: 2 Analog output (4-20mA)
AI	AI module: 2 Analog input (4-20mA)
EP	Pulse module: 2 pulse output
BA	BACnet module: BACnet protocol
64M	64Mbit Memory (8Mbyte)
③ Rated Input voltage(Vph-N/ Vph-ph) and current	
V1	57.7/100V (via PT), 5A
V2	57.7/100V (via PT), 1A
V3	220/380V (direct), 5A
V4	220/380V (direct), 1 A

V5	120/208V (direct), 5A
V6	240/415V (direct), 5A
V7	277/480V (direct), 5A
V8	63.5/110V (via PT), 5A
V9	120/208V (direct), 1 A
V10	240/415V (direct), 1 A
V11	277/480V (direct), 1 A
V12	63.5/110V (direct), 1 A
V13	398/690V(direct), 5A
④ Rated input frequency (Not choose will be deem as 50Hz)	
F1	50Hz
F2	60Hz
⑤ Aux. power supply (Not choose will be deem as P1)	
P1	85~265Vac, 85 ~ 265Vdc, 45-65Hz
P2	100 ~ 420Vac , 100 ~ 400Vdc, 45~60Hz

For example:

Order No.: PMAC770N-SSR-V3 indicates the meter is the basic type + 8 digital input + 2 relay out, rated input 220/ 380V, 5A, rated input frequency 50Hz, and the Aux. power supply: 85~265Vac, 85 ~ 265Vdc.

3. Packing list



Packing box included:

1. PMAC770 Basic Unit (and optional modules)
2. User Manual

4. Figure and Terminals

4.1 Dimension

Unit: mm

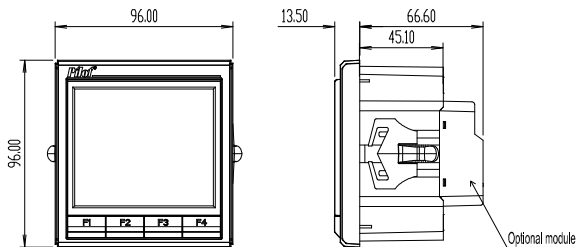

4.2 Installation

Unit: mm

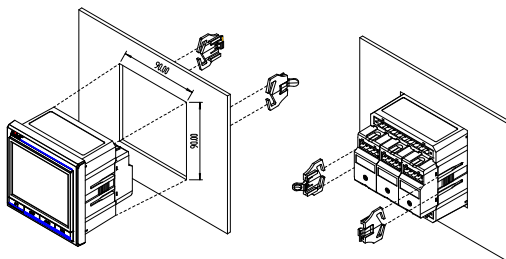

4.3 Terminals

4.3.1 Terminal of Basic Unit

No.	Mark	Definition
1	NC	Null
2	N/-	Negative wire, Aux. power supply AC/ DC 220V
3	L/+	Positive wire, Aux. power supply AC/ DC 220V
4	V1	Phase A voltage
5	V2	Phase B voltage
6	V3	Phase C voltage
7	VN	Voltage neutral line
8	485-	RS485 com port-1, negative wire
9	485+	RS485 com port -1, positive wire
10	RL21	Relay output 2, positive
11	RL22	Relay output 2, negative
12	RL11	Relay output 1, positive
13	RL12	Relay output 1, negative
14	SG	Digital input, common earth
15	S3	Digital input 3, positive
16	S2	Digital input 2, positive
17	S1	Digital input 1, positive
18	I1+	In line, phase A current
19	I1-	Out line, phase A current

20	I2+	In line, phase B current
21	I2-	Out line, phase B current
22	I3+	In line, phase C current
23	I3-	Out line, phase C current

4.3.2 Terminals of DI module (PMAC770-S):

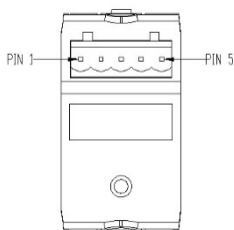

Digital Input Module		
(one meter maximum can add 2 DI module)		
No.	Mark	Definition
PIN1	EX S4(S8)	Digital input 4 (or 8) , positive
PIN2	EX S5(S9)	Digital input 5 (or 9) , positive
PIN3	EX S6(S10)	Digital input 6 (or 10) , positive
PIN4	EX S7(S11)	Digital input 7 (or 11) , positive
PIN5	EX SG	Common earth

4.3.3 Terminals of DO module (PMAC770-R):

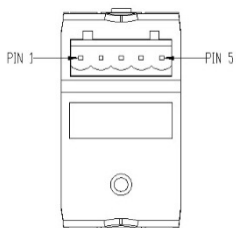

Relay Output Module		
(One meter can add one DO module only)		
No.	Mark	Definition
PIN1	EX RL22	Extend relay-2 output 2
PIN2	EX RL21	Extend relay-2 output 1
PIN3	NC	Null
PIN4	EX RL12	Extend relay-1 output 2
PIN5	EX RL11	Extend relay-1 output 1

4.3.4 Terminals of AO module (PMAC770-AO):

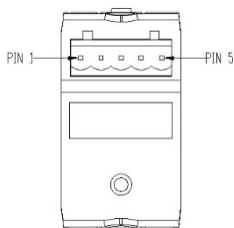

Analog Output Module

(One meter can add one AO module only)

No.	Mark	Definition
PIN1	EX AO2	Positive wire, analog output 2
PIN2	EX AG	Negative wire, analog output 2
PIN3	NC	Null
PIN4	EX AO1	Positive wire, analog output 1
PIN5	EX AG	Negative wire, analog output 1

Note: The AO module must be inserted to the 3rd interface from left to right, back view.



AO module

4.3.5 Terminals of AI module (PMAC770-AI):

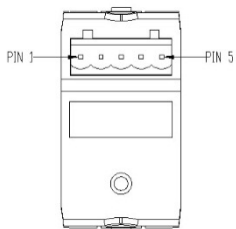

Analog Input Module		
(One meter can add one AI module only)		
No.	Mark	Definition
PIN1	EX AI1	Positive wire, analog input 1
PIN2	EX AG	Negative wire, analog input 1
PIN3	NC	Null
PIN4	EX AI2	Positive wire, analog input 2
PIN5	EX AG	Negative wire, analog input 2

4.3.6 Terminals of RS485 Module (PMAC770-C):

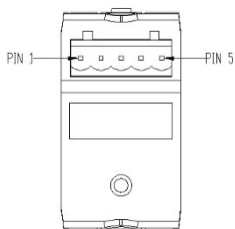

Extend RS485 Communication Module (One meter can add one C module only)		
No.	Mark	Definition
PIN1	NC	Null
PIN2	NC	Null
PIN3	NC	Null
PIN4	EX 485-	Extend RS485 output, negative
PIN5	EX 485+	Extend RS485 output, positive

4.3.7 Terminals of Pulse Output Module (PMAC770-EP):

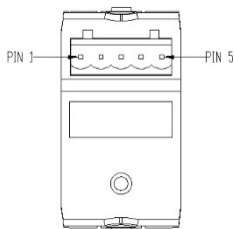

Pulse Output Module		
(One meter can add one PO module only)		
No.	Mark	Definition
PIN1	EX P1+	Pulse output for kWh, positive
PIN2	EX P1-	Pulse output for kWh, negative
PIN3	NC	Null
PIN4	EX P2+	Pulse output for kvarh, positive
PIN5	EX P2-	Pulse output for kvarh, negative

5. Connection Mode and Wiring

PMAC770 supports 2 kinds of connection mode: 3P4W and 3P3W..

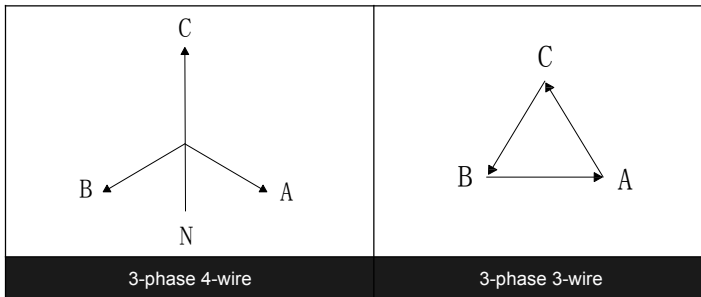

(1) 3-phas 4-wire, no PT, 3CT:

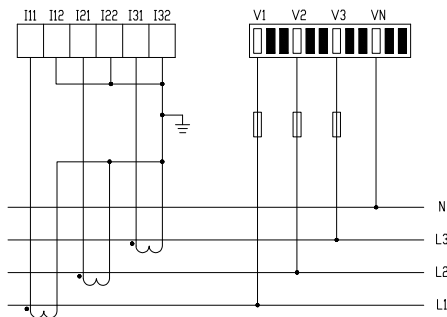

(2) 3-phas 4-wire, 3PT, 3CT:

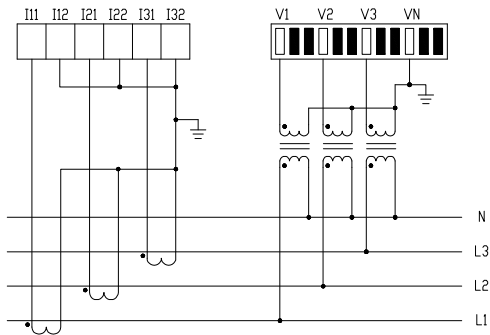

(3) 3-phas 3-wire, no PT, 3CT:

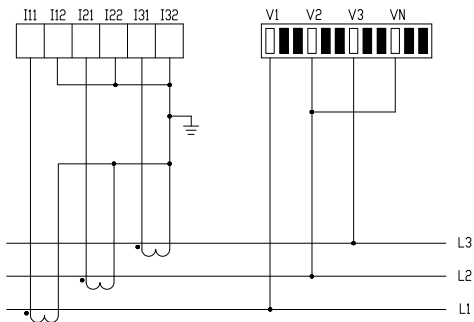

(4) 3-phas 3-wire , no PT, 2CT:

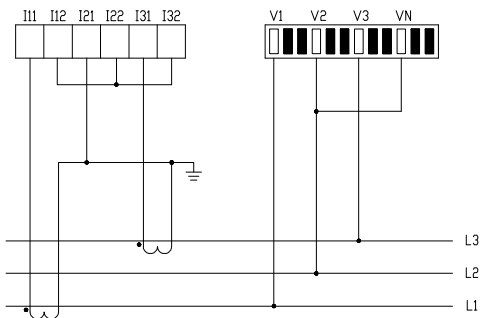

(5) 3-phas 3-wire , 2PT, 3CT:

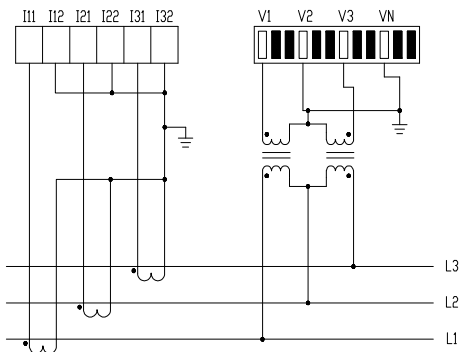



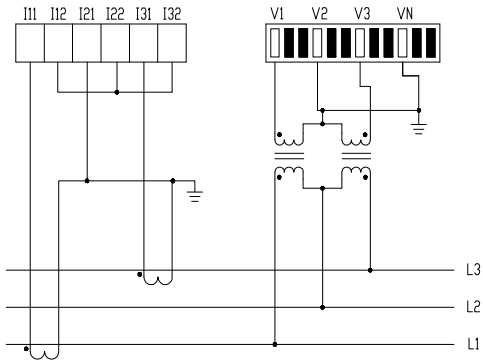

(6) 3-phas 3-wire, 2PT, 2CT:



6. Display and Key-press Operation

6.1 Display Instruction



- 1: Menu
- 2: Item
- 3: Load rate: $\text{Load rate} = \text{average current} / \text{rated current} \times 100\%$
- 4: DI/ DO status: means ON, means OFF
- 5: Communication:  means no communication,
 1 means RS485 port 1,  2 means RS485 port 2.
- 6: Unit
- 7: Data display area
- 8: Key prompt area
- 9: Alarm: when display  , it mean there is error.

6.2 Keys

6.2.1. General Information

PMAC770 has a back-light LCD, user-friendly display.

Users can query/ set different information by 4 keys according to the menu prompt.

If press the keys, the back-light will be on lasting for 60s. If no continue pressing key, the back-light will be off.



Keys: F1, F2, F3, F4

6.2.2. Menu Prompt and Keys Instruction

Keys or Prompt	Instruction
--->	To next item, it is for menu rolling search
↶	Return to previous menu or cancel
SET	Setting
Menu prompt	Enter into the menu of corresponding parameter.

6.3 Map of Display Data

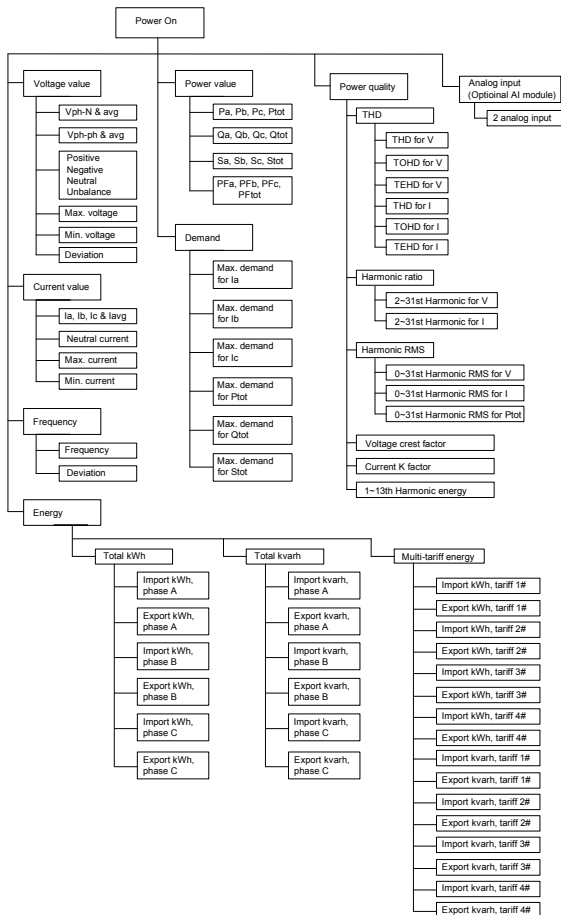

7. Query Procedure

7.1 Initial Display

When PMAC770 is powered on, the initial display as below:

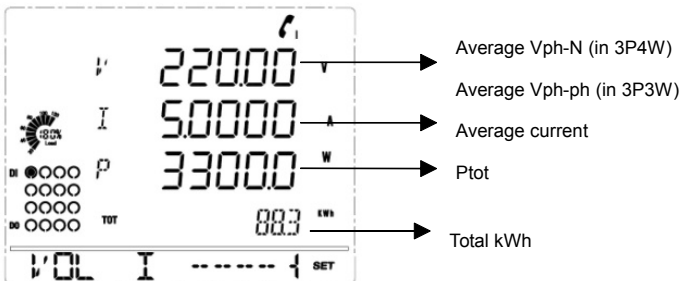

Menu Prompt:

VOL: Voltage menu

I: Current menu

FRE: Frequency menu

POWER: Power menu

ENERGY: Energy menu

EQ: Power quality menu

DMD: Demand menu

A-I: Analogy input menu

SET: Setting

7.2 Voltage Value

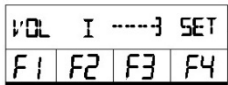

Press key F1 × 1

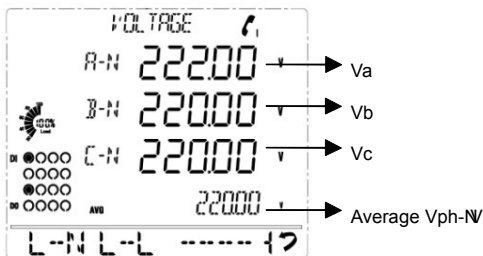

Menu Prompt:

L-N: Vph-N & average menu

L-L: Vph-ph & average menu

UNBAL: Positive (U-2), Negative (U-1), Neutral (U-0), Unbalance rate

MAX.: Max. Vph-N or Max. Vph-ph & time stamp

MIN: Min. Vph-N or Min. Vph-ph & time stamp

REC: Voltage deviation record

Max. Voltage & Time Stamp



Record of Voltage Deviation

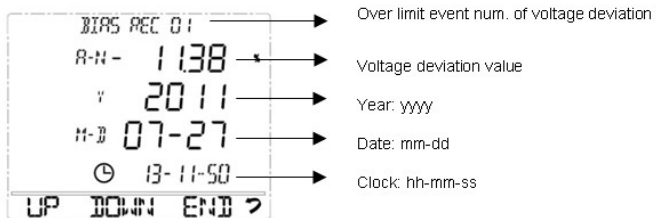

Menu Prompt:

UP: Page up to previous record

DOWN: Page down to next record

START: Event occurs time

END: Event end time

7.3 Current Value

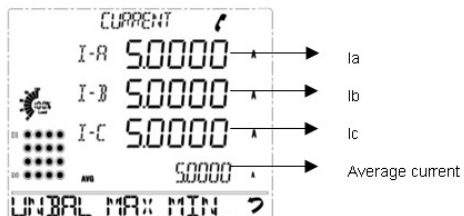
**Menu Prompt:**

UNBAL: Positive (I-2), Negative (I-1), Neutral (I-0)

Max.: Max. current & time stamp

Min.: Min. current & time stamp

7.4 Frequency



Menu Prompt:

REC: Frequency deviation record

Record of Voltage Deviation



Over limit event num. of frequency deviation

Frequency deviation value

Year: yyyy

Date: mm-dd

Clock: hh-mm-ss

Menu Prompt:

UP: Page up to previous record

DOWN: Page down to next record

START: Event occurs time

END: Event end time

7.5 Power Value

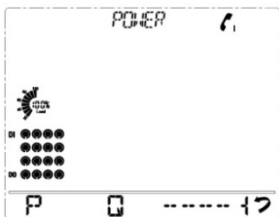

Menu Prompt:

P: Active power, per phase & total

Q: Reactive power, per phase & total

S: Apparent power, per phase & total

PF: Power factor, per phase & total

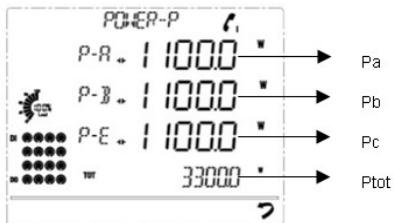

Pa

Pb

Pc

Ptot

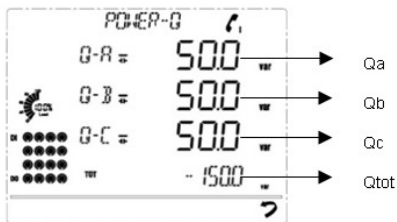

Qa

Qb

Qc

Qtot

7.6 Energy

Total kWh

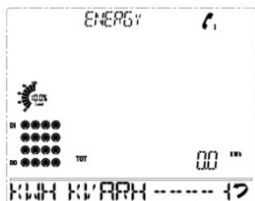

Menu Prompt:

KWh: Total kWh, Phase A/ B/ C kWh (Imp. & Exp.)

KVARh: Total kvarh, Phase A/ B/ C kvarh (Imp. & Exp.)

TOU: Import kWh (or kvarh) of each tariff (tariff 1#, tariff 2#, tariff 3#, tariff 4#),

Export kWh (or kvarh) of each tariff (tariff 1#, tariff 2#, tariff 3#, tariff 4#).

Import kWh, phase A

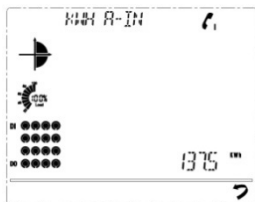

Import kvarh, phase A

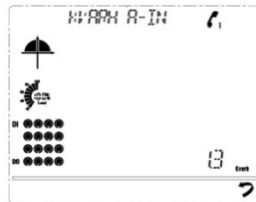

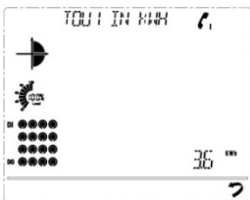
Import kWh, tariff-1

7.7 Harmonic

Harmonic display

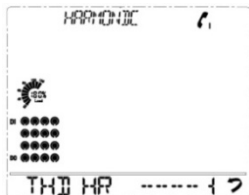

Menu Prompt:

THD: THD for V (or I)

TOHD for V (or I)

TEHD for V (or I)

HR (Harmonic ratio):

2~31st harmonic for V

2~31st harmonic for I

RMS (Harmonic RMS):

0~31st harmonic RMS for V

0~31st harmonic RMS for I

0~31st harmonic RMS for Ptot

CF: Voltage crest factor

K-FAC: Current K factor

ENERGY: kWh of 1~13th harmonic

THD for V

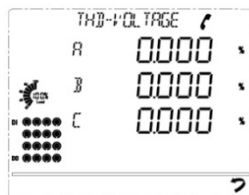

2nd harmonic for V

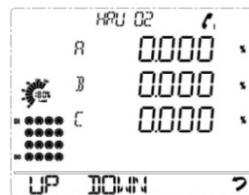

RMS, DC component for V

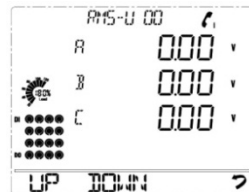

Voltage crest factor

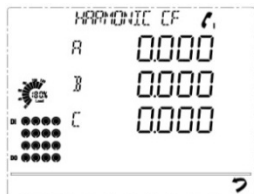

Current K factor

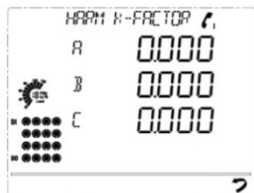

Total kWh of fundamental

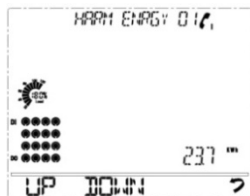

7.8 Demand

Demand menu

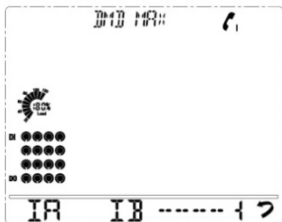

Menu Prompt:

IA: Max. demand for Ia & time stamp

IB: Max. demand for Ib & time stamp

IC: Max. demand for Ic & time stamp

P: Max. demand for Ptot & time stamp

Q: Max. demand for Qtot & time stamp

S: Max. demand for Stot & time stamp

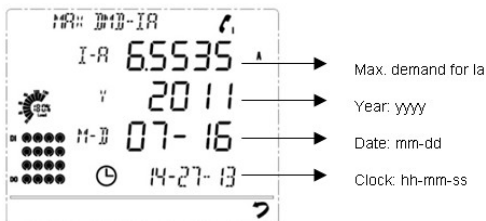

7.9 Analog Input (Optional)

Analog input menu:

(If PMAC770 add the AI module, it will has this menu)

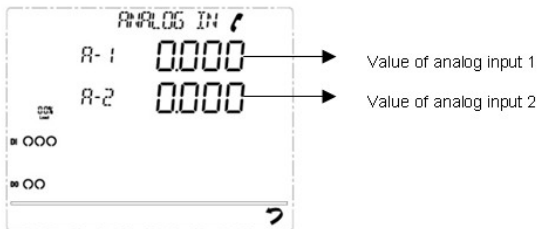

8. Setting

8.1 Instruction

In initial display, we can see the "SET" prompt, press F4 to SETUP menu.

Initial display

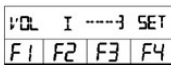

Press key F4 x 1



Set up menu

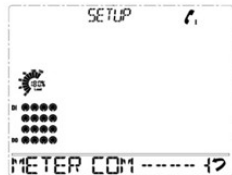

Menu Prompt:

METER: Meter setting

COM: Communication setting

CLEAR: Clear data

RELAY: Relay setting

AO: Analog output setting

LIMIT: Under/ over limit setting

ERROR: Error record



After go into each setting menu, there is a prompt "CODE", it means User need to enter the correct password.

Press key F3 x 1

Enter the password: 0001

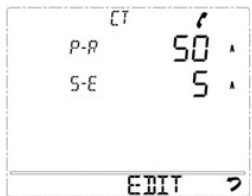

Default password is "0001"

Super password is "2011"

After enter the correct password, there is "EDIT" prompt, it means User can edit the parameter.



flashing

UP: increase the value

LEFT: cursor move to left

ENTER: enter to confirm the value



: Cancel, back to menu

8.2 Setting Site-map

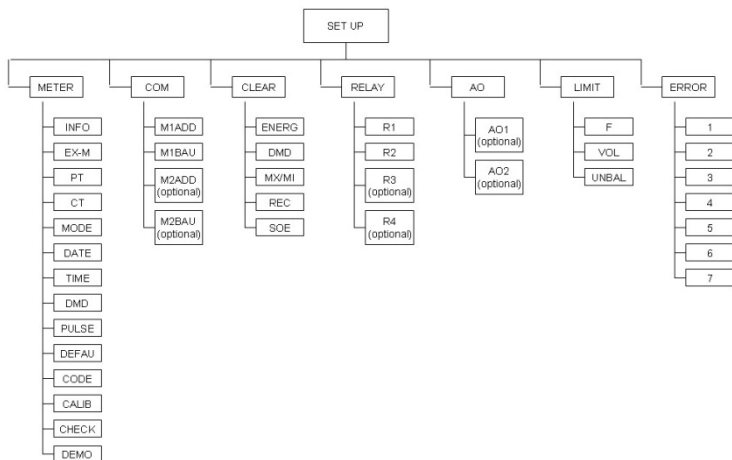

8.3 METER—Meter Setting Menu

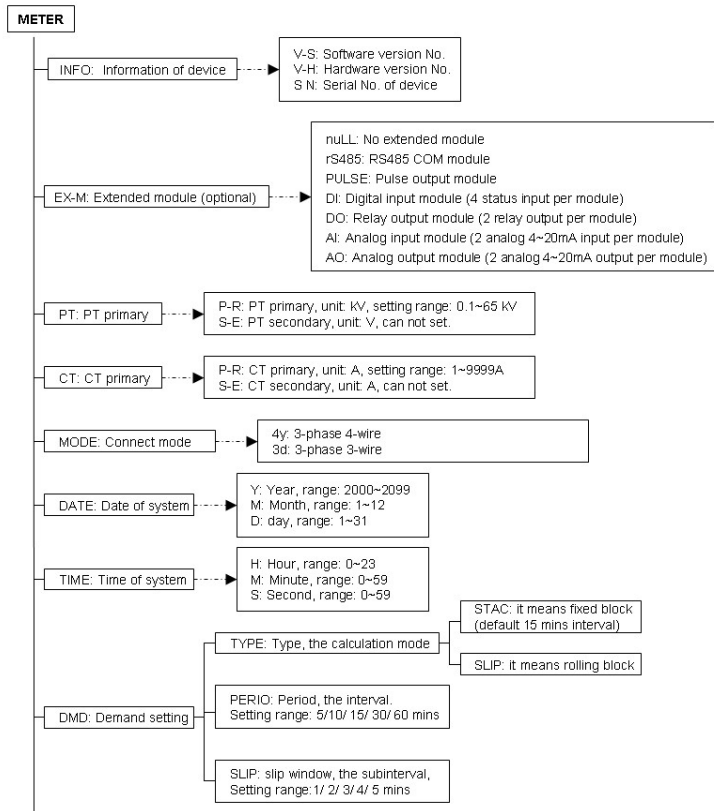

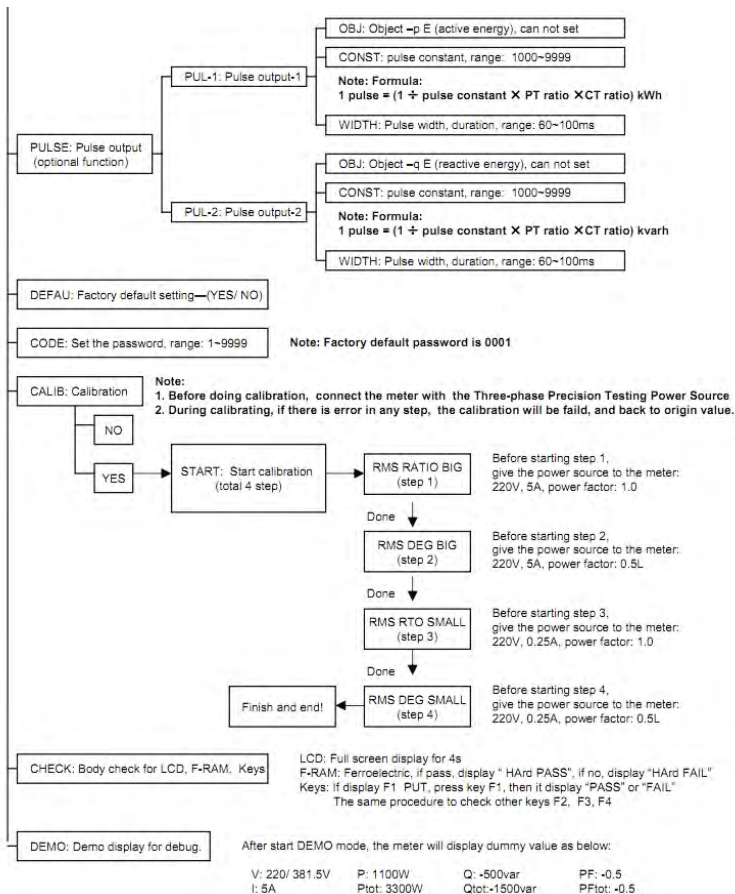

8.4 COM—Communication Setting Menu

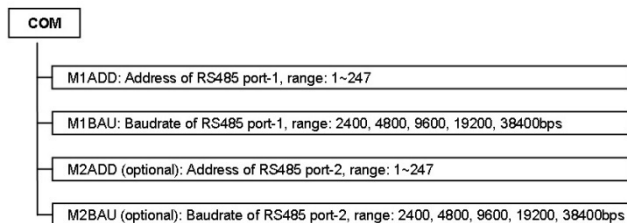

8.5 CLEAR—Clearing Data Menu

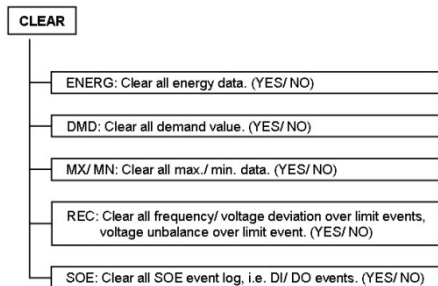

8.6 RELAY—Relay Setting Menu

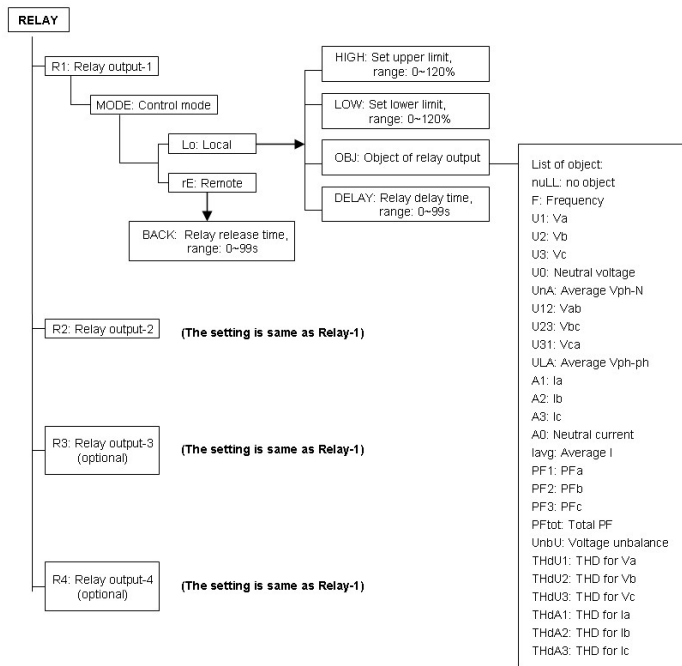

8.7 AO—Analog Output Setting Menu (Optional)

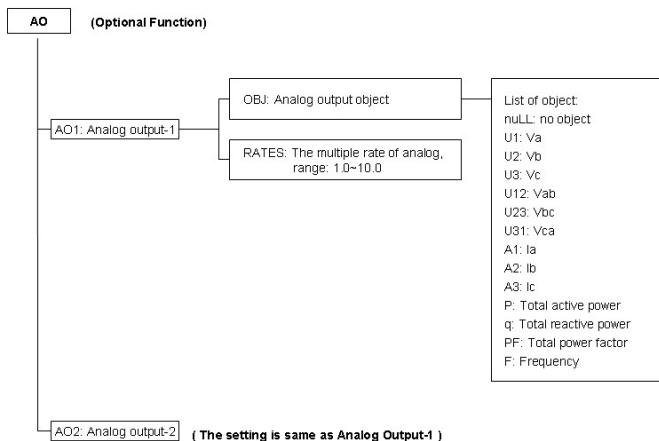

8.8 LIMIT—Deviation Limit Setting Menu

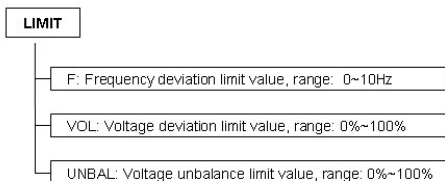

8.9 ERROR

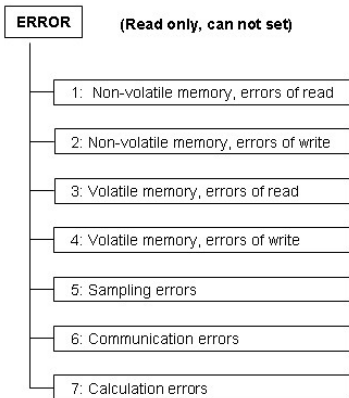

Note: The meter can record 10 errors for each type.

The prompt “  ” appears on LCD if there is error.

Please contact the After-sales Dept. for solution.

9. Measuring Function Description

Parameter	Accuracy	Resolution	Measuring Range
Voltage	0.2%	0.01V	Direct: 5%~120% of rating PT primary: 0~65.00kV PT secondary: 100Vph-ph or 110V
Current	0.2%	0.001A	CT primary: 0~9,999A CT secondary: 1 A or 5A
Power	0.5%	0.001 kW/kvar/ kVA	Per phase: 0~649.9MW/ Mvar/ MVA Total: 0~1949.8MW/ Mvar/ MVA
Power factor	0.5%	0.001	-1.000~+1.000
Frequency	1.0%	0.01Hz	45~ 65 Hz
Active energy	0.5%	0.1kWh	0~ 99,999,999.9 kWh
Reactive energy	2.0%	0.1kvarh	0~ 99,999,999.9 kvarh
THD	1.0%	0.001	0~100.0%
Individual harmonic	1.0%	0.001	0~100.0%
Un-balance	1.0%	0.001	0~100.0%

9.1 Voltage

PMAC770 has several type of voltage input for option, as below:

Description	Rated input	Symbol in model No.	Connection	Mode
High voltage meter	57.7/ 100V	V1, V2	Via PTs	3-phase 4-wire
	63.5/110V	V8, V12		3-phase 3-wire
Low voltage meter	120/208V	V5, V9	Direct input	3-phase 4-wire
	220/380V	V3, V4		
	240/415V	V6, V10		
	277/480V	V7, V11		
	398/ 690V	V13		

While measuring voltage lower than 398Vph-N / 690Vph-ph, PMAC770 do not need to connect external PTs, it can be input directly. While measuring other higher voltage, PMAC770 need external PTs. If PMAC770 is connected via PTs, the PTs direct affect the measurement accuracy of the meter. So, users should consider the linearity and accuracy rate of PTs.

Normally, Overload capacity of voltage measurement is 120% of rated voltage. Users should pay attention on the voltage input when using the device, and avoid getting wrong data caused by over-scope measurement. Max. rated measuring range is

65KV.

Connection mode of voltage input can be set via panel or communication.

When choose low voltage meter, the connection mode is fixed 3-phase 4-wire

When choose high voltage meter, user can set the connection mode: 3-phase 4 wire
or 3-phase 3-wire

Tips: It is recommended to clear the energy after change the connection mode

PT primary setting range: 0.1KV to 65KV, and PT primary value should not lower than the rated voltage value.

9.2 Current

Only when adopt CTs can PMAC770 measures current.

CT secondary rated output must comply with rated current input of PMAC770 (5A or 1A). When connecting external CTs, users must make sure the current is not open circuit. Otherwise, primary excitation will generate high voltage at secondary circuit, causing personal injury or death and equipment damage.

Normally, overload capacity of current measurement is 120% of rated current. Users should pay attention to the current input when using the device, and avoid getting wrong data caused by over-scope measurement.

Rated measuring range of current is 0 to 9999A.

CT primary setting range is from 1A to 9999A, and it should not smaller than the rated

current value.

9.3 Active power

PMAC770 calculates three phase active power and total active power: P_a , P_b , P_c , and P_{tot}

Measuring range: per phase 0~ 649.9MW, total: 0~ 1949.8MW.

9.4 Reactive power

PMAC770 calculates three phase reactive power and total reactive power: Q_a , Q_b , Q_c , and Q_{tot}

Measuring range: per phase 0~ 649.9MVar, total: 0~ 1949.8MVar

Attention
<ol style="list-style-type: none">1. Both active power and reactive power value have signs.2. When wiring, users should pay attention to the phase sequence of voltage and current. Otherwise, it may cause wrong measuring data. Besides, it is necessary to connect the CTs terminals correctly; otherwise there will be negative power value.

9.5 Apparent power

PMAC770 calculates three phase apparent power and total apparent power: S_a , S_b , S_c and S_{tot} .

Measuring range: per phase 0~ 649.9MVA, total: 0~ 1949.8MVA

9.6 Power factor

PMAC770 measures per phase power factor and total power factor: PFa, PFb, PFc and PFtot. Measuring range: -1.000 to +1.000.

Like active / reactive power value, the wiring and CTs terminals connecting will affect actual calculated value of power factor.

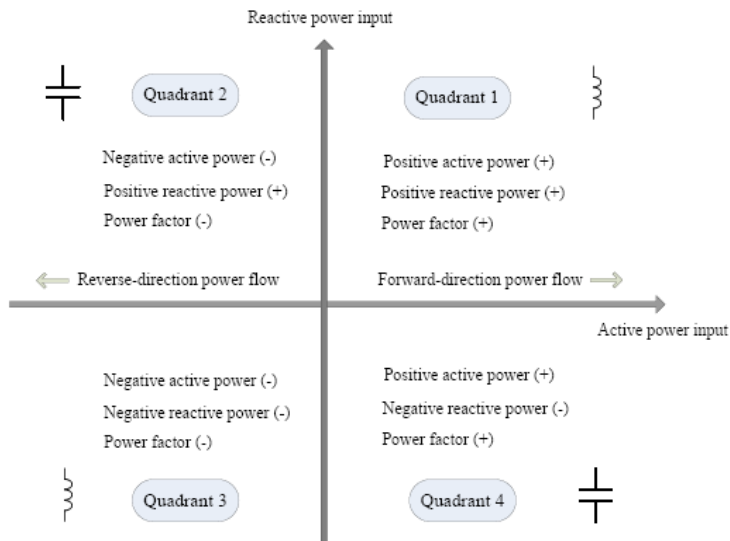

9.7 Frequency

In different connection modes, PMAC770 samples the system frequency from different channels. In 3-phase 3-wire connection mode, PMAC770 samples the frequency from line AB voltage channel. In other connection modes, it samples frequency from phase A voltage channel. In case phase A voltage is failure, it samples frequency from phase C voltage channel. In case both phase A and C voltage are failure, it samples from phase B voltage channel.

9.8 Demand calculation

PMAC770 provides demand analysis for three phase current, total active power, total reactive power and total apparent power.

PMAC770 supports two demand modes: Fixed Block and Rolling Block.

Users can set demand interval as 5min, 10min, 15min, 30min or 60min.

In Fixed Block mode, users do not need to set the subinterval.

In Rolling Block mode, users should set subinterval the subinterval: 1min, 2 min, or 3 min. Show as below sheet:

Optional Intervals (mins)	Programmable Subintervals (mins)
5	1
10	1 or 2
15	1 or 3
30	1, 2, or 3
60	1, 2, or 3

Max. Demand: In nonvolatile memory, PMAC770 maintains a running maximum for power and current demand values with date & time stamp, called “Max. Demand”.

User can read the demand value from LCD or RS485 communication.

Below figure is a sample of Rolling Block mode:

(Demand intervals is 10 mins, subintervals is 2 mins.)

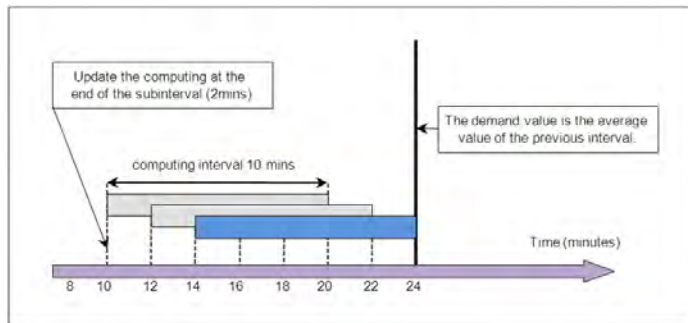

9.9 Phase sequence detect

PMAC770 can detect the voltage phase sequence. After input 3-phase voltage and 3-phase current signals to the meter, users can press the button to display real-time phase voltage or line voltage and see the present phase sequence.



Correct connection!



Wrong! Phase B and C same



Wrong! Phase A and B opposite

Note: Only after provide 3 phase voltage and current signal to the meter can it detect the phase sequence.

10. Power Quality Analysis

Item	Parameter	Measuring Range	Accuracy
THD	THD for voltage	0~100%	Class B
	TOHD for voltage	0~100%	Class B
	TEHD for voltage	0~100%	Class B
	THD for current	0~100%	Class B
	TOHD for current	0~100%	Class B
	TDHD for current	0~100%	Class B
Harmonic Ratio	HR for voltage	2~31 st	Class B
	HR for current	2~31 st	Class B
Harmonic RMS	Harmonic voltage RMS	0~31 st	Class B
	Harmonic current RMS	0~31 st	Class B
	Harmonic power RMS	0~31 st	Class B
	Harmonic energy RMS	1~13 th	Class B
Other	Voltage crest factor	/	Class B
	Current K factor	/	Class B
	Frequency deviation	0~100%	Class B
	Voltage deviation	0~100%	Class B
	Voltage unbalance	0~100%	Class B

10.1 General Description

Harmonics are any “non-linear” current or voltage in an electrical distribution system. With these harmonics flowing into the power system, it will affect the reliability of the transformers and protection relays, and it will accelerate the ageing of metalized polyester film, increase the power loss of transmission, and disturb communication or measurement accuracy of instruments.

PMAC770 provides up to 31st harmonics analysis which is strong helpful for power quality analysis.

10.2 THD

PMAC770 measures voltage and current harmonic up to 31st, and calculates THD, TOHD (Odd) and TEHD (Even).

Users can read THD data (%) from the LCD or communication. For example, the data is 20.00, the actual THD value is 20.00%

10.3 Harmonic Ratio for Voltage

PMAC770 measures up to 31st voltage harmonic. Users can read 2~31st voltage harmonic (%) from the LCD or communication. For example, the data is 10.00, the actual harmonic value is 10.00%

10.4 Harmonic Ratio for Current

PMAC770 measures up to 31st current harmonic. Users can read 2~31st current harmonic (%) from the LCD or communication. For example, the data is 10.00, the actual harmonic value is 10.00%

10.5 Voltage Crest Factor

PMAC770 measures 3 phase voltage crest factor, data resolution: 0.001. If no voltage input, the CF value is 0. Users can read CF value from the LCD or communication.

Crest Factor Formula:

$$CF = 1.414 \times \sum_{h=1}^N U_h / U_1$$

In the formula, U_h is the h harmonic RMS, U_1 is fundamental harmonic RMS. N is the highest order harmonic.

10.6 Current K Factor

PMAC770 measures 3 phase current K factor, data resolution: 0.001. If no current input, the K Factor value is 0. Users can read K Factor value from the LCD or communication.

K Factor Formula:

$$K \text{ Factor} = \sum_{h=1}^N (I_h \times h)^2 / \sum_{h=1}^N (I_h)^2$$

In the formula, I_h is the h harmonic current ratio, h is the harmonic order number, N is the highest order harmonic.

10.7 Harmonic Voltage RMS

PMAC770 measures 0 ~31st harmonic voltage RMS, data resolution: 0.01V. Users can read every order of harmonic voltage RMS from the LCD or communication.

10.8 Harmonic Current RMS

PMAC770 measures 0 ~31st harmonic current RMS, data resolution: 0.0001A. Users can read every order of harmonic current RMS from the LCD or communication.

10.9 Harmonic Power RMS

PMAC770 measures 0 ~31st harmonic power (total active power) RMS, data resolution: 0.1W. Users can read every order of harmonic power RMS from the LCD or communication.

10.10 Harmonic Energy RMS

PMAC770 measures 0 ~13th harmonic energy (total kWh) RMS, data resolution: 0.1 kWh. Users can read every order of harmonic energy RMS from the LCD or communication.

10.11 Frequency Deviation

PMAC770 calculates the Frequency Deviation, data resolution: 0.01Hz

Frequency deviation means the difference between the actual frequency and the nominal frequency

Formula: *Frequency Deviation = Actual Frequency – Nominal Frequency*

Users can set the *Nominal Frequency* in PMAC770 via communication. There are

50Hz or 60Hz for option.

Besides, PMAC770 records the over-limit event for frequency deviation. Users can set a limit value for the frequency deviation.

When the real-time frequency deviation is out of limit, PMAC770 will record the event with time stamp, its duration time and the Peak value. PMAC770 can store 30 events log for frequency deviation.

10.12 Voltage Deviation

PMAC770 calculates 3-phase voltage deviation which is the percentage of deviation compared with its nominal value.

Formula:

$$\text{Voltage Deviation (\%)} = (\text{Actual voltage} - \text{Nominal voltage}) / \text{Nominal voltage} \times 100\%$$

In above formula, the *Nominal voltage* is rated voltage. The voltage deviation has a negative or positive sign.

Besides, PMAC770 records the over-limit event for voltage deviation. Users can set a limit value for the voltage deviation.

When the real-time voltage deviation is out of limit, PMAC770 will record the event with time stamp, its duration time and the Peak value. PMAC770 can store 30 events log for voltage deviation.

10.13 Voltage Unbalance Rate

PMAC770 calculates 3 phase voltage unbalance rate. Data resolution: 1%.

Formula:

$$\varepsilon_U = \frac{U_2}{U_1} \times 100\%$$

U1 is 3-phase voltage positive-sequence component RMS

U2 is 3-phase voltage negative-sequence component RMS

Besides, PMAC770 records the over-limit event for voltage unbalance. Users can set a limit value for the voltage unbalance.

When the real-time voltage unbalance is out of limit, PMAC770 will record the event with time stamp, its duration time and the Peak value. PMAC770 can store 30 events log for voltage unbalance. Meanwhile, PMAC770 also records the Peak unbalance in present day/ month/ history.

Note: PMAC770 do not calculate the current unbalance.

11. Energy and Multi-tariff Energy Statics

11.1 General Description

According to the direction of power, PMAC770 calculates 4 quadrant kWh/ kvarh, and statics multi-tariff energy and history energy data,

PMAC770 accumulates the energy value since it was powered on at the first time. (In case that users clear the energy to 0, the meter will re-accumulate the energy from 0)

Until the value reach 99,999,999.9 kWh/ kvarh, it will auto-turnover.

Under different connection mode, PMAC770 accumulates the energy in different way, as below sheet:

Connection mode	Energy calculation
3-phase 4-wire	Per phase 4 quadrant energy Total energy Multi-tariff energy History energy
3-phase 3-wire	Total energy Multi-tariff energy History energy

Note: User can clear the energy to 0 on panel by keys, or clear from communication.

11.2 Active Energy

PMAC770 calculates the active energy according to the accumulated active power. And it distinguishes the direction of active/ reactive power to separately calculate per phase/ total active energy in 4 quadrants.

11.3 Reactive Energy

PMAC770 calculates the reactive energy according to the accumulated reactive power. And it distinguishes the direction of active/ reactive power to separately calculate per phase/ total reactive energy in 4 quadrants.

11.4 Multi-tariff Energy

PMAC770 statistics the import/ export kWh and import/ export kWh in different tariff.

PMAC770 supports 2 tariff lists. Users can set the 2 lists separately. Each tariff list can be set max. 8 periods in one day and 4 different tariff (F1, F2, F3, F4 means 4 kinds of tariff, and F1 for Sharp, F2 for Peak, F3 for Flat, F4 for Valley).

Below example for setting the tariff lists:

Tariff List	Num. of period	Period order	Starting time (to end time)	Tariff
Tariff List 1	8	1st period	00:00 (to 03:00)	F1
		2nd period	03:00 (to 06:00)	F2
		3rd period	06:00 (to 09:00)	F4
		4th period	09:00 (to 12:00)	F3
		5th period	12:00 (to 15:00)	F1
		6th period	15:00 (to 18:00)	F4
		7th period	18:00 (to 21:00)	F2
		8th period	21:00 (to 00:00)	F3
Tariff List 2	5	1st period	06:00 (to 10:00)	F1
		2nd period	10:00 (to 12:00)	F2

	3rd period	12:00 (to 14:00)	F1
	4th period	14:00 (to 20:00)	F3
	5th period	20:00 (to 06:00 of next day)	F4

There are 2 modes to calculate the multi-tariff energy: Date Mode and Holiday Mode.

Under Date Mode, it divides one year (365 days) into 2 periods

Under Holiday Mode, it divides the days by working day and holiday. Working day is from Monday. to Friday. Holiday is from Saturday to Sunday.

Below example for setting the mode:

Mode	Time Zone 1 (use the Tariff List 1)	Time Zone 2 (use the Tariff List 2)
Date Mode	From Apr.1 to Sep. 30	From Oct.1 to Mar.31 of next year
Holiday Mode	From Mon. to Fri.	From Sat. to Sun.

Attention

1. Users can divide one day (24 hours) up to 8 periods, and set 4 tariff maximum.
2. Each period must >15 minutes, and the duration must be a multiple of 15.
3. The starting time of each period must be in ascending order
4. The multi-tariff only can be set from communication. It can't be set on panel.
5. If 2 different periods use the same tariff, the meter will combine the energy of 2 periods together.
6. The system default that: Time Zone 1 uses the Tariff List 1, and Time Zone 2 use the Tariff List 2. User can't change it.

11.5 History Energy

PMAC770 statistics daily energy of last 31 days, and statistics monthly energy of last 12 months. User can read the history energy as below:

Daily energy of last 31 days	Import kWh/ kvarh, Export kWh/ kvarh
Monthly energy of last 12 months	(Each tariff) Import kWh/ kvarh, (Each tariff) Export kWh/ kvarh

12. Record Function

12.1 General Description

In order to facilitate users to do various fault analysis, PMAC770 provides up to 100 records of SOE event and 30 records of over-limit event for frequency deviation/ voltage deviation/ voltage unbalance. Users can easily and quickly position seeking the fault from the SOE event counter.

Additional, PMAC770 also provides records of Max. demand and Max./ Min. data for users doing analysis of electricity consumption.

12.2 SOE Event Log

PMAC770 can record the event of switch and relay position (i.e. ON/ OFF status.) The event is recorded with time stamp which is stored in PMAC770 by UNIX time format. Time resolution is 1ms. The UNIX time is a system for describing instances in

time, defined as the number of seconds that have elapsed since the midnight 00:00:00 on January 1, 1970.

From PILOT software, users can see the event as below format:

No.	Event
1	2011-07-28 09:31:34 792ms Relay 1 ON

. For more details, please refer to ***PMAC770 Modbus Register List***

12.3 Frequency Deviation Record

User can set the frequency deviation over-limit value in PMAC770 (default limit: 0.2Hz, setting range: 0~10Hz).When the $| \text{frequency deviation} | > \text{limit}$, PMAC770 records the deviation starting time, ending time, and the Max. deviation (value with sign). Users can find the record from panel and communication.

Once the event happen, users can find the record in PILOT software as below format:

No.	Event
1	2011-07-28 09:31:34 to 2011-07-28 09:32: 15, frequency deviation, Max. value is 0.50Hz

For more details, please refer to ***PMAC770 Modbus Register List***

12.4 Voltage Deviation Record

User can set the voltage deviation over-limit value in PMAC770 (default limit: 10%, setting range: 0~99.99%).When the $| \text{voltage deviation} | > \text{limit}$, PMAC770 records the deviation starting time, ending time, and the Max. deviation (value with sign).

Users can find the record from panel and communication.

Once the event happen, users can find the record in PILOT software as below format:

No.	Event
1	2011-07-28 15:02:25 to 2011-07-28 15:30:46, voltage deviation, Max. value is -14%

For more details, please refer to ***PMAC770 Modbus Register List***

12.5 Voltage Unbalance Record

User can set the voltage unbalance over-limit value in PMAC770 (default limit: 20%, setting range: 0~100%).When unbalance > limit, PMAC770 records the unbalance starting time, ending time, and the Max. unbalance value. Users can find the record from panel and communication.

Once the event happen, users can find the record in PILOT software as below format:

No.	Event
1	2011-07-28 06:05:25 to 2011-07-28 06:28:35, voltage unbalance Max. unbalance value is 24%

For more details, please refer to ***PMAC770 Modbus Register List***

12.6 Max. Demand Record

PMAC770 records the max. demand for 3-phase current, total active power, total reactive power, total apparent power.

When the instant demand exceeds the history maximum demand, PMAC770 will record the new maximum data with time stamp.

User can clear the Max. demand record from panels and communication.

12.7 Max./ Min. Record

PMAC770 records the max./ min. for 3-phase voltage (ph-N and ph-ph)/ 3-phase current/ active power/ reactive power/ apparent power.

When the instant value exceeds the history maximum or lower than history minimum, PMAC770 will record the new max./ min. data with time stamp.

User can clear the Max./ Min. record from panels and communication.

13. Setpoint Alarm

13.1 General Description

PMAC770 provides setpoint alarm for all parameters. It supports monitor 2 parameters at the same time.

There are 2 setpoint types: Over-limit and Under-limit. Users can set the limit as per requirement.

13.2 Setpoint Object

PMAC770 can monitor 27 kinds of parameters, as below:

Object	Parameter
Voltage	Va, Vb, Vc, neutral voltage, average phase voltage, Vab, Vbc, Vca, average line voltage
Current	Ia, Ib, Ic, neutral current, average current
Power factor	PFa, PFb, PFC, PFtot
Frequency	Frequency
Power quality	Voltage unbalance, Phase A voltage THD Phase B voltage THD Phase C voltage THD Phase A current THD Phase B current THD Phase C current THD
Null	No object

13.3 Alarm Condition

13.3.1 Set over/ under limit

After set the monitoring object, users need to set the alarm condition, i.e. set the over/ under limit value. For setting range of the parameter, please refer to ***PMAC770 Modbus Register List***

Note: When setting the over/ under limit, if the limit value is out of measuring range, the setting will be invalid.

Take the frequency for example:

Measuring range for frequency: 45-65Hz, default rated voltage is 50Hz. Setpoint limit range: 0-120%

If users set the under-limit: 20% (20% of rating, i.e. 10Hz), which is out of measuring range, the setpoint is invalid, it will not alarm.

13.3.2 Set the delay time

After set the over/ under limit, users need to set the delay time. Setting range: 0~99s. Only it satisfy two conditions that, the monitored object over/ under limit and lasting to delay time, will the setpoint channel be activated. If set the delay time to 0, it means setpoint channel will be activated once the object over/ under limit.

13.4 Alarm Output

When the setpoint channel of one relay output is activated, the relay will output signal. One SOE event is record.

13.5 Example

Users want to monitor phase A voltage and set the over-limit to 120% U_e, linking with relay 1, set the delay time to 30s. If the actual phase A voltage exceed to the limit and lasting to 30s, then the relay 1 will output the signal. If the phase A voltage return to limit value within 30s, the relay 1 will not respond.

Note
<ol style="list-style-type: none">1. If set the delay time to 0, it means setpoint channel will be activated once the object over/ under limit.2. If no setting the monitor object, it means no relay alarm function.

14. Auxiliary Function

14.1 Communication

PMAC770 provides one RS485 port in basic module, and provides another one as optional function. The two RS485 ports are independent from each other. Normally, on site, one RS485 is enough. Please refer to below connection diagram.

Attention: In the field, in order to avoid signal reflecting, it's common to connect a 120Ω resistance at the end of RS485 network for signal matching.

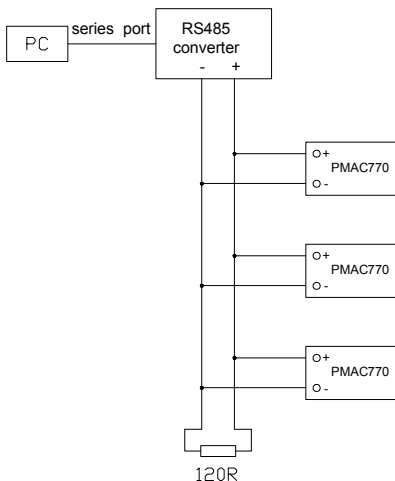

14.1.1 Communication Medium

The communication medium is No. 22 STP (Shielded twisted pair). Maximum 32 units of meters can be connected in one RS485 circuit. If there is no repeater, the communication bus should not longer than 1,200m.

14.1.2 Communication Protocol

PMAC770 support standard Modbus-RTU protocol. For more details, please refer to ***PMAC770 Modbus Register List***.

14.1.3 Communication Parameters

Communication between master and slave device will be available under correctly setting the communication parameters.

The parameters include:

- ◇ Address: Every meter has its exclusive address. Setting range: 1~247.
- ◇ Baudrate of RS485 port 1: 2400, 4800, 9600, 19200, 38400 (programmable)
- ◇ Baudrate of RS485 port 2: 2400, 4800, 9600, 19200, 38400 (programmable)

14.1.4 Strong Power Prevention

The RS485 terminals of PMAC770 have the strong power burning prevention function. It means that, even there is 220VAC access to the RS485 terminals (within 5 minutes), the communication board will not be burnt. And the communication will be recovered once cut off the power.

14. 2 Status Input

PMAC770 provides 3 status input as basic feature apply to monitor the ON/ OFF position of breakers or switchers etc.. Besides, it also provides up to 8 optional status input which is flexible to meet different requirement.

The status input of PMAC770 is wet contact, requires connecting external power supply 220VAC/ 50Hz. The example of connection as below:

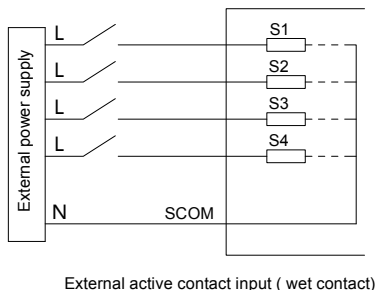

Generally, when external contact is ON, the linking status input channel on PMAC770 LCD will be ON. When external contact is OFF, the linking status input channel on PMAC770 LCD will be OFF.

From the communication, 0 means OFF, 1 means ON.

14.3 Relay Output

PMAC770 basic unit provides 2 relay output, and Users can add one optional Relay Output Module which provides the other 2 relay output.

Relay node capacity: 250VAC/5A. There are 2 kinds of relay control mode: Local control and Remote control.

Under local mode, the reply is used for the setpoint function to monitor the parameter. In case the parameter is over/ under limit, the relay will respond, and output signal. (Please refer to **Chapter 13 Setpoint Alarm** for more description).

Under remote control mode, users can remote control the relay according to requirement.

The action of relay is different in two modes. So, users should firstly distinguish the relay is in remote control mode or in local control mode.

The default relay control mode of PMAC770 is remote control. Users can change the mode by keys on panel or via communication.

- ◆ **Remote control (external):** The relay is controlled by a PC or PLC using commands through communication.

Release time: Release time is defined as the time since from the relay status is changed by PC or PLC to the relay recover. If set the release time to 0, it means that the relay will not recover.

User can set the release time by keys on panes or via communication.

- ◆ **Local control (internal)** - The relay will respond once the electrical parameters satisfy alarm conditions. (Please refer to **Chapter 13 Setpoint Alarm** for more description).

Delay time: Delay time is defined as the time since over/ under limit happens. If set the delay time to 0, it means the relay responds as soon as over/ under limit happens.

When the relay is under remote control mode, even though the local control conditions have been set, the relay will not respond. The relay mode must be set to local control mode, otherwise, it will not alarm for over/ under limit.

14.4 4~20mA Analog Input (optional module)

In some projects, for example where request to monitor the main transformers, to measure the non-electric parameters such as the temperature or pressure, users can choose one AI module. Each AI module provides 2 channels of 4~20mA analog input. Each meter can only support one AI module.

14.5 Pulse Output (optional module)

Each meter can only support one PO module. The PO Module provides 2 channels of pulse output for statistic the energy.

The first channel is for active energy (kWh), second channel is for reactive energy (kvarh). The formula is $1 \text{ pulse} = 1 + \text{pulse constant} \times \text{CT} \times \text{PT}$ (kWh or kvarh).

Pulse constant: 1000 ~9999 programmable, factory default set 1000

Pulse width: 60~100ms programmable, factory default set 80ms

User can set the pulse constant and width by keys on panel or via communication.

Below figure is a typical example of pulse output wiring.

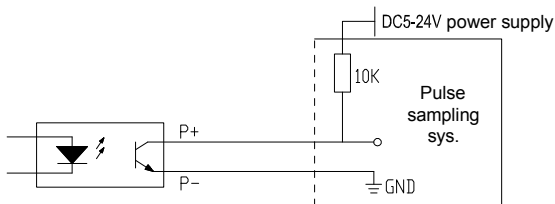

14.6 Analog Output (optional module)

Each meter can only support one AO module. The AO module provides 2 channels of

4~20mA analog output.

Output maximum load is 500 ohm, output range is 4~20mA, overload: 1.2 times.

The analog output channels can be defined to associate with various parameters include 3-phase voltage (ph-ph, or ph-N), 3-phase current, total active power, total reactive power, total power factor, frequency etc.

Below figure is a typical example of pulse output wiring.

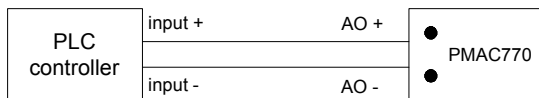

The Analog Output Curve as below, Magnification factor is λ

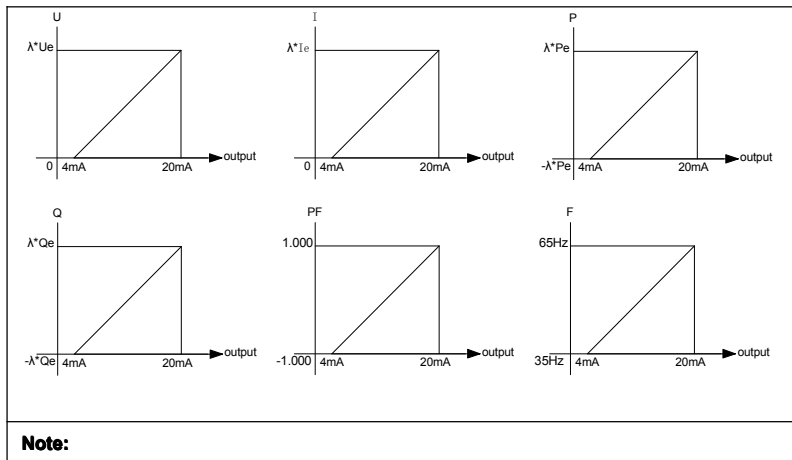

$$P = \frac{(P_{\lambda} - 12)}{8} \times P_e \times \lambda \times CT \times PT$$

In above formula:

is the real measurement of analog value,

unit: mA.

is the rated power, unit: W or var.

is the magnification factor. Range: 1~10.

Factory default set =1

$$P_e = \sqrt{3} \times U_e \times I_e$$

In above formula:

is rated voltage (ph-ph).

is rated current

The analog output channels can be defined to associate with any one of below parameters

Analog output object	
Voltage	Phase voltage: Va, Vb, Vc
	Line voltage: Vab, Vbc, Vca
Current	Ia, Ib, Ic
Active power	Ptot
Reactive power	Qtot
Power factor	PFtot
Frequency	F

Remark: if set the analog output object to frequency or Ptot or F, it's meaningless to set the magnification factor, default =1

14.7 Memory (optional module)

The memory space of the Memory module is 64M bit. Each meter can only support one Memory module.

Note:

(1) In case the power meter is suddenly power off, it could cause the data lost in one hour.

(2) The data can be stored after continuous power on for one hour.

14.7.1 Install

This Memory Module can be directly inserted to the extend interface of PMAC770 basic unit. After insert the memory module, the meter should be restarted to recognize the memory function.

Before insert or pull out the Memory Module, users should power off the meter. Otherwise, it can damage to the meter.

14.7.2 Specification of Memory Module

Parameter	Specification
Space	64Mbit
Speed	500~1000ms
Temperature	-20~55℃
Service life	10 years
Data save cycle	1 year
Data save interval	5 min

14.7.3 Function Description

The memory module works with the PMAC770 basic unit to save the measured data regularly (interval: 5 min). The save cycle is one year. It saves the parameters as below:

- 3-phase voltage
- 3-phase current
- Frequency
- Voltage unbalance rate
- 3-phase power factor
- THD for voltage
- Demand current
- Demand active power
- Demand reactive power
- Demand apparent power

14.7.4 Read the Data from Memory Module

The PMAC770 only support to read the data from RS485 communication. Please refer to the ***PMAC770 Modbus Communication Protocol*** for more details.

15. Technical Specification

Metering	True RMS, 1 sec refresh time
Input	<p>Rated current : 1A or 5A</p> <p>Rated voltage:</p> <p>Optional 120V, 220V, 240V, 277V, 398Vph-N (direct)</p> <p>Or 100V, 110Vph-ph (via PT)</p> <p>PT secondary: 100V or 110Vph-ph (optional)</p> <p>Frequency: 50 or 60 Hz (optional)</p>
Overload	<p>120% of rated, continuously</p> <p>Instantaneous current: 10 times / sec</p> <p>Instantaneous voltage: 2 times / sec</p>
Status input	<p>Wet contact.</p> <p>Require external power supply</p> <p>For high voltage meter, require power supply for DI:</p> <p>100Vac \pm 25%.</p> <p>For low voltage meter, require power supply for DI:</p> <p>220Vac \pm 25%.</p>
Relay output	Node capacity: 250Vac/5A
Pulse output	<p>Pulse output value: 1000~9999imp/ kWh</p> <p>Pulse width: 60~100ms programmable</p>

Starting current	0.1%I _n
Power frequency withstand voltage	AC 2KV/minute
Insulation resistance	≥50MΩ
Impulse withstand voltage	4kV (peak), 1.2/50μS
Power supply	When order No. is P1: 85~265Vac, 85~265Vdc When order No. is P2: 100~420Vac, 100~400Vdc
Power loss	When order No. is P1, power loss <10VA When order No. is P2, power loss<15VA
Communication	RS485 serial, support Modbus-RTU Baud rate: 2400, 4800, 9600, 19200, 38400bps Address: 1~247
Dimension (L x W x H)	Panel: 96 x 96 x 13.5 mm Cut-out: 96 x 96 x 58.6mm (basic unit) 96 x 96 x 80.1 mm (basic unit + optional module)
IP index	IP52 (front panel) and IP30 (case)
Weight	Basic unit: approx 400gr.
	Operating temperature: -10℃~ +55 ℃

Environment	Storage temperature: -40℃~ +70 ℃
	Humidity: 5%~95% non-condensing

Parameter	Accuracy	Resolution	Measuring Range
Voltage	0.2%	0.01V	Direct: 5%~120% of rating
			PT primary: 0~65.00kV
			PT secondary: 100Vph-ph or 110V
Current	0.2%	0.001A	CT primary: 0~9,999A
			CT secondary: 1 A or 5A
Power	0.5%	0.001 kW/ kvar/ kVA	Per phase: 0~649.9MW/ Mvar/ MVA
			Total: 0~1949.8MW/ Mvar/ MVA
Power factor	0.5%	0.001	-1.000~+1.000
Frequency	0.5%	0.01Hz	45~ 65 Hz
Active energy	0.5%	0.1kWh	0~ 99,999,999.9 kWh
Reactive energy	2.0%	0.1kvarh	0~ 99,999,999.9 kvarh
THD	1.0%	0.001	0~100.0%
Individual harmonic	1.0%	0.001	0~100.0%
Un-balance	1.0%	0.001	0~100.0%
Time	±0.5s		0~ 24 hours

Item	Standard	Level
Oscillatory waves immunity test	IEC61000-4-12:1995	III
Electrostatic discharge immunity	IEC61000-4-2:2001	III
Radiated,radio-frequency,Electromagne field immunity test	IEC61000-4-3:1998	IV
Electrical fast transient/burst immunity test	IEC61000-4-4:1998	III
Surge immunity test	IEC61000-4-5:2005	III
Immunity to conducted disturbances, induced by radio-frequency fields	IEC61000-4-6:1998	III
Power frequency magnetic field immunity test	IEC61000-4-6:2001	III
Electromagnetic emission limit value	IEC60255-25:2000	OK
Power frequency immunity test	IEC61000-4-8:2001	A

16. Maintenance and Trouble Shooting

Possible problem	Possible cause	Possible solution
The meter has no indication after the control power supply is imposed.	The power supply fails to be imposed on the meter.	<p>Check if the correct working voltage has been imposed on the L/+ and N/- terminals of the meter.</p> <p>Check if the fuse for the control power supply has been burnt down.</p>
The measured value is not correct or does not conform to the expectation.	The voltage measurement is not correct.	<p>Check if the neutral point has been connected reliably.</p> <p>Check if the measured voltage matches the rated parameter of the meter.</p> <p>Check if PT ratio has been set correctly.</p>
	The current measurement is not correct.	<p>Check if the measured current matches the rated parameter of the meter.</p> <p>Check if CT ratio has been set correctly.</p>

	<p>The power measurement is not correct.</p>	<p>Check if the connection mode has been set correctly.</p> <p>Check if the phase sequence corresponding to the voltage and the current is correct.</p> <p>Check if the wiring of current terminals are correct</p>
<p>The DI status is not change</p>	<p>The DI operating voltage is not correct.</p>	<p>Check if the types of external nodes match the rated parameters of the meter.</p> <p>Check if the external connection is correct.</p>
<p>The relay no respond</p>	<p>The relay does not receive the control command.</p>	<p>Check if the communication link is correct.</p>
	<p>The working mode of the relay is not correct.</p>	<p>Check if the current relay is under the correct control mode.</p>

	The operating time has not been set correctly.	Check the setting of the operating time of the relay. For the specific information, refer to the content regarding relays of the operation manual.
No analog output.	The analog is set as “disable” or wrong object.	Check through communication the setting of analog.
No pulse output or incorrect pulse output	The setting of the pulse object or constant is wrong.	Check if the pulse output channels is activated Check if the pulse constant is set correctly.
The upper end device can not communicate with the meter.	Communication address error	Check if the address of the meter is consistent with its definition or if there are more than two identical addresses in the same network.
	Baudrate error	Check if the baudrate setting on the meter is consistent with the upper end device.

	The communication link has not been connected to the terminal resistor.	Check if the 120-Ohm resistor has been connected.
	The communication link suffers interference.	Check if the communication-shielding layer has been earthed effectively.
	The communication line is interrupted.	Check if the communication cable has been disconnected.

Notice:

- PILOT reserves the right to modify this manual without prior notice in view of continued improvement.
- Technical Consulting: +86 15916202620
- After-sale Services: +86 15916202800
- Email: pilot166@pmac.com.cn